

Art. 92143618

LKZ 41332

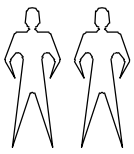

≈2h

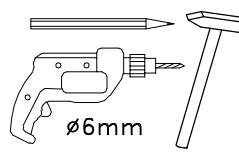

∅6mm

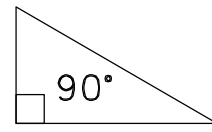

90°

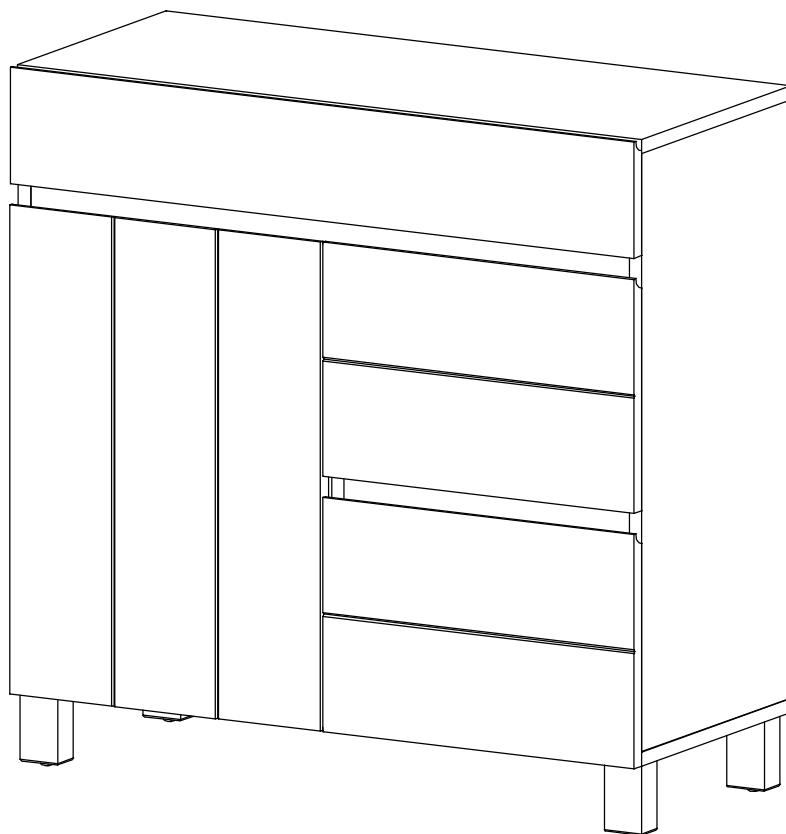
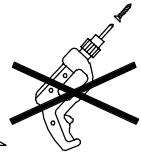









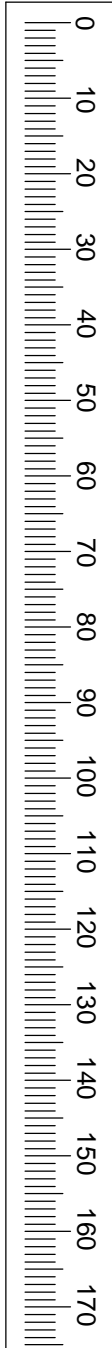
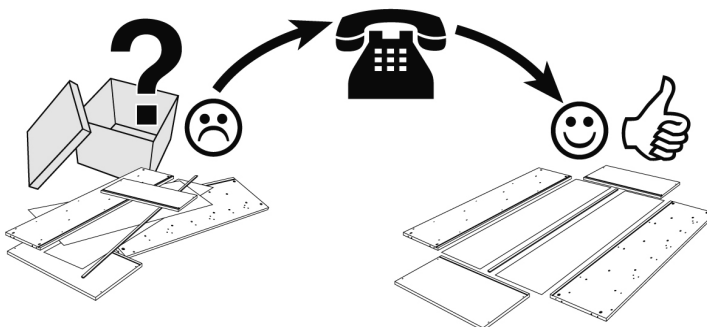
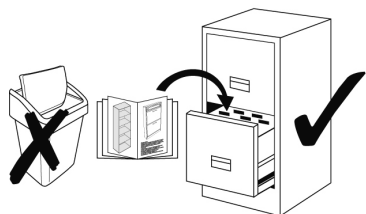



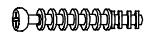

Service • Assistenza • Dienstverlening • Serwis  
 Servis • Szerviz • Сервисная служба

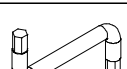
Name • Nom • Nome • Naam  
 Nazwa • Jméno • Názov • Név  
 Denumire • Isim • Название

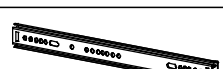
Nr • No • N° • Номер • Č • Sz

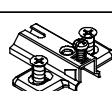
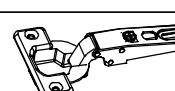
Typ • Type • Típus • Tipo  
 Тип

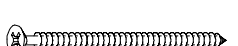

H1	 x44 ø 8x30	D5	 x40 ø 15x12,5	D2	 x40 ø 5/11x34
D1	 x4	D4	 x14 ø 17	D36	 x14
A5	 x1 4 mm	D18	 x2 ø 12	A27	 x4 ø 7x50
E31	 x6 27x310	A8	 x6 M4x12	A15	 x12 ø 5,8x11
G84	 x2	G39	 x2 ø 35	A1	 x6 ø 3,5x15
D31	 x1	H8	 x1 ø 6x35	A69	 x1 ø 4x60

Teil Nr. Pièces Nr. Pieces Nr. Часть Ном. Kawalek Nr. Parça No Kusù Nr. Kusov Nr. Pezzi Nr. Nr piесе. Darab száma. Stukken Nr. Kārtas Nr.	Anzahl Quantité Quantity Количество Ilość Miktar Množství Množstvo Quantità Cantitatea Mennyiség Hoeveelheid Skaitis	Kasten Nr. Colli Nr. Colli Nr. Коробка Ном. Polu Nr. Kutusu Nr. Kolonka Č. Počet balení Colli Nr. Nu pachete Colli száma. Colli Nr. Kastes Nr.	Maß, mm Dimensions, mm Dimensions, mm Размеры, mm Wymiary, mm Boyutlar, mm Rozměry, mm Rozmery, mm Dimensioni, mm Dimensiuni, mm Méterek, mm Afmetingen, mm Izmēri, mm	✓
01	1	2 / 2	802 x 331 x 16	
02	1	2 / 2	802 x 331 x 16	
03	1	2 / 2	680 x 330 x 16	
04	1	2 / 2	680 x 330 x 16	
05	1	2 / 2	504 x 329 x 16	
06	1	2 / 2	769 x 329 x 16	
07	1	2 / 2	769 x 48 x 16	
08	1	1 / 2	367 x 66 x 16	
09	1	2 / 2	385 x 310 x 16	
13	1	1 / 2	310 x 100 x 16	
14	1	1 / 2	310 x 100 x 16	
15	2	1 / 2	310 x 164 x 16	
16	2	1 / 2	310 x 164 x 16	
19	1	1 / 2	733 x 99 x 16	
20	2	1 / 2	331 x 163 x 16	
24	2	1 / 2	342 x 304 x 3	
25	1	1 / 2	744 x 304 x 3	
26	1	1 / 2	512 x 394 x 3	
27	1	1 / 2	512 x 375 x 3	
28	1	1 / 2	778 x 168 x 3	
30	4	1 / 2	80 x 48 x 35	
34	1	1 / 2	556 x 399 x 43	
36	1	1 / 2	801 x 132 x 18	
37	2	1 / 2	399 x 266 x 18	



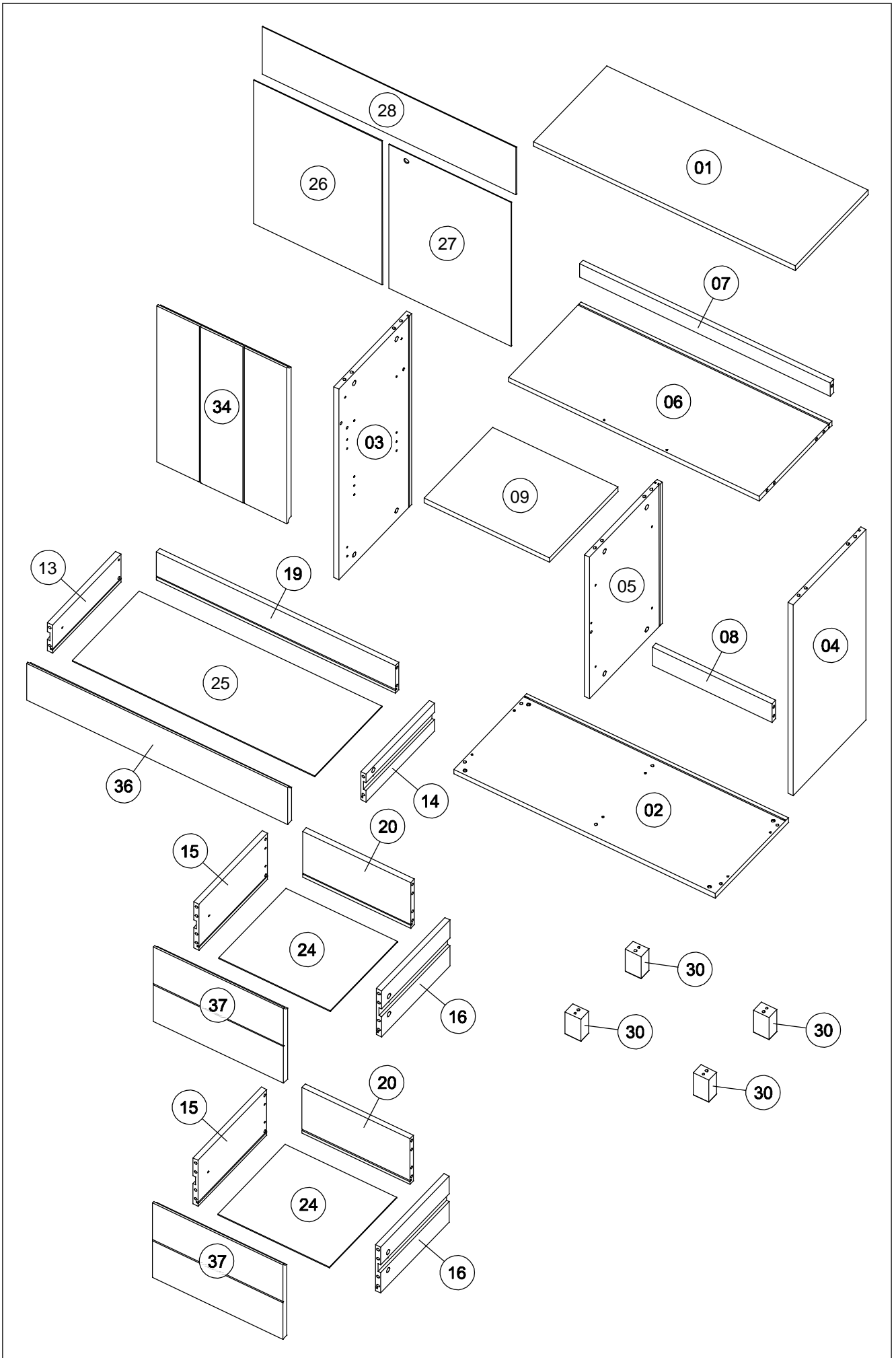

67632

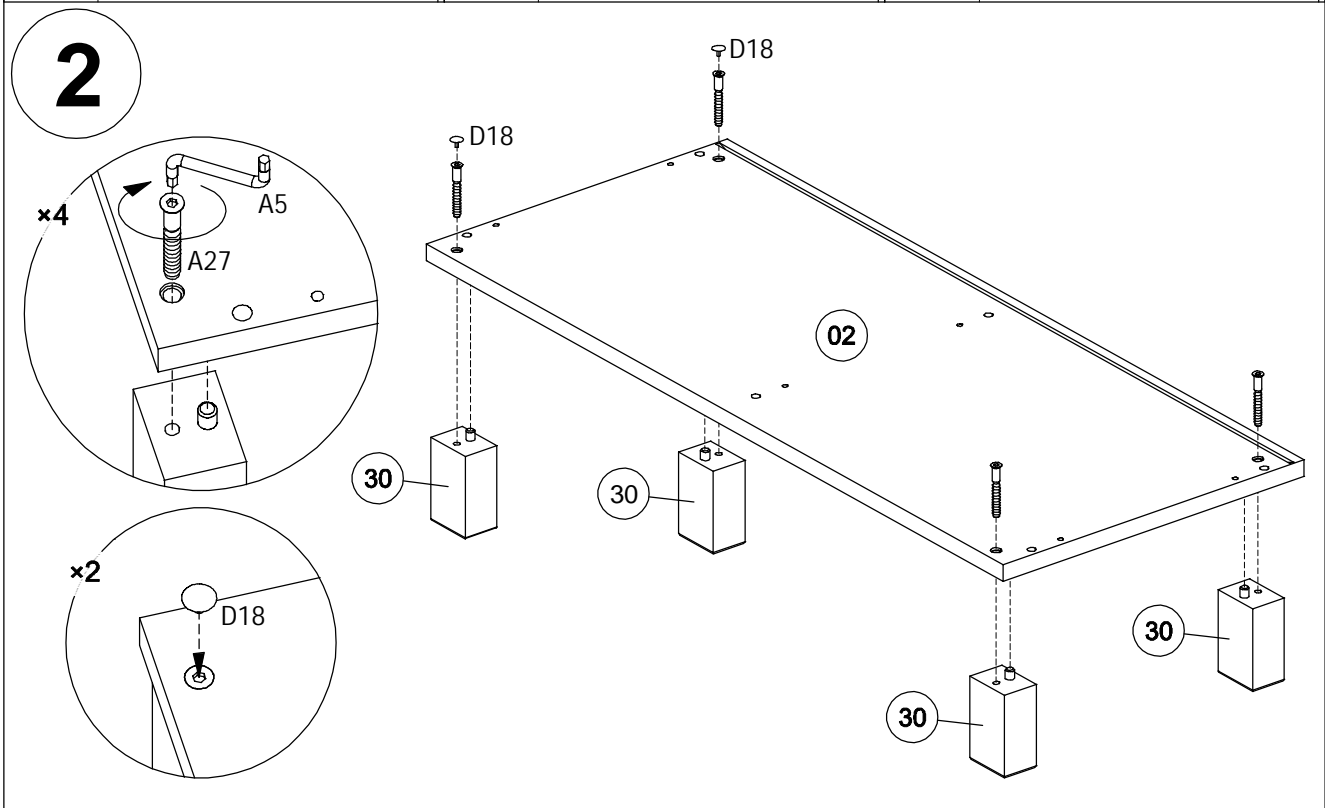
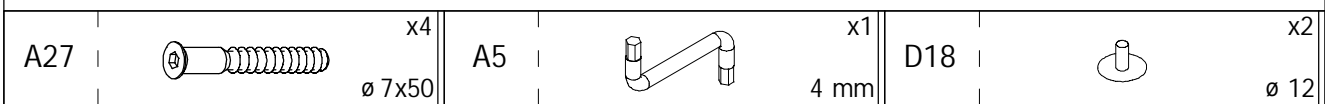
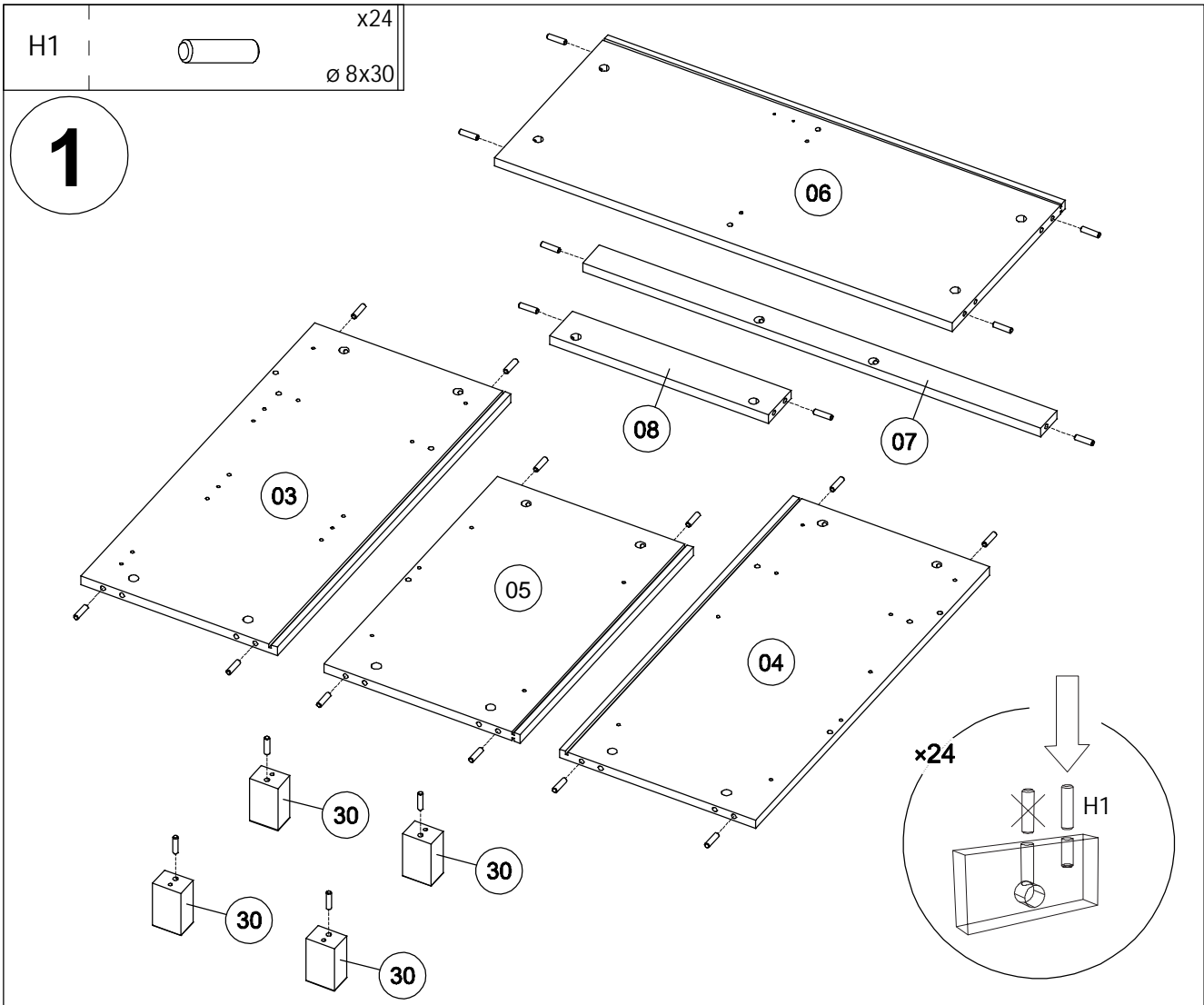

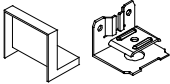

67632

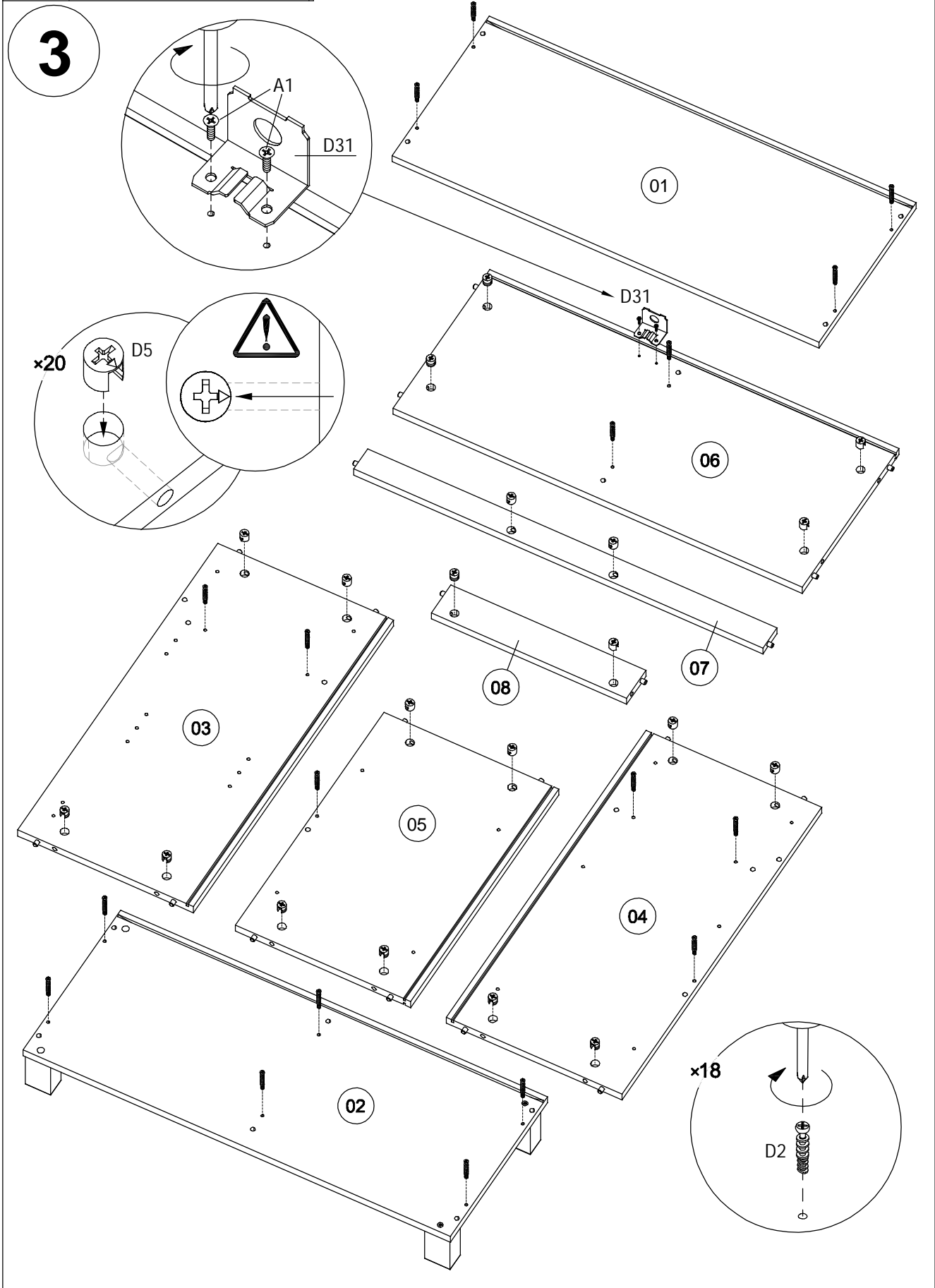

67632

D31	 x1	D2	 x18 ø 5/11x34	D5	 x20 ø 15x12,5
A1	 x2 ø 3,5x15				

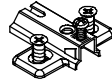
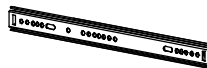

G84	 x2	E31	 x6 27x310	A15	 x12 ø5,8x11
-----	---	-----	---	-----	---

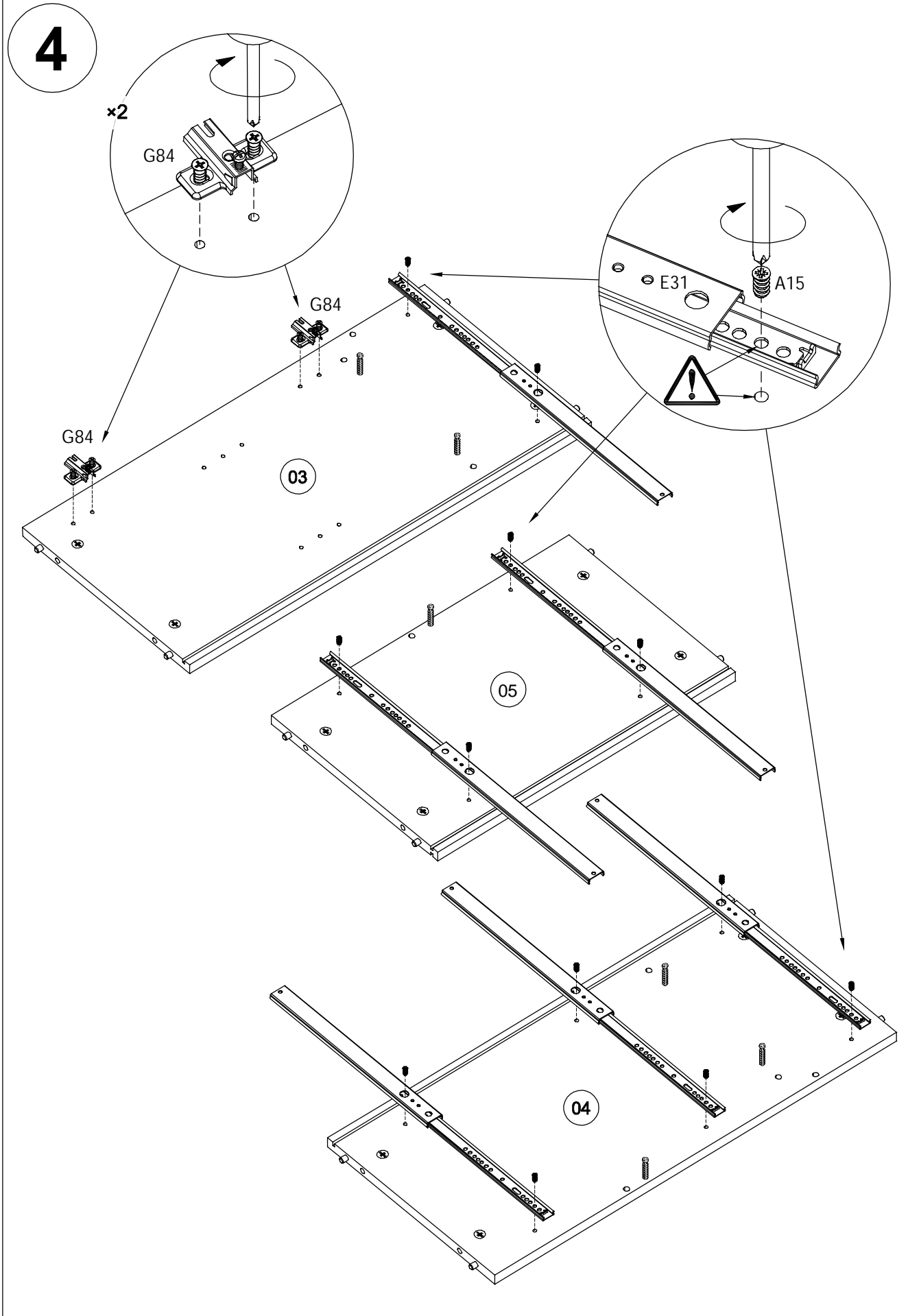

D2



x2

ø 5/11x34

5

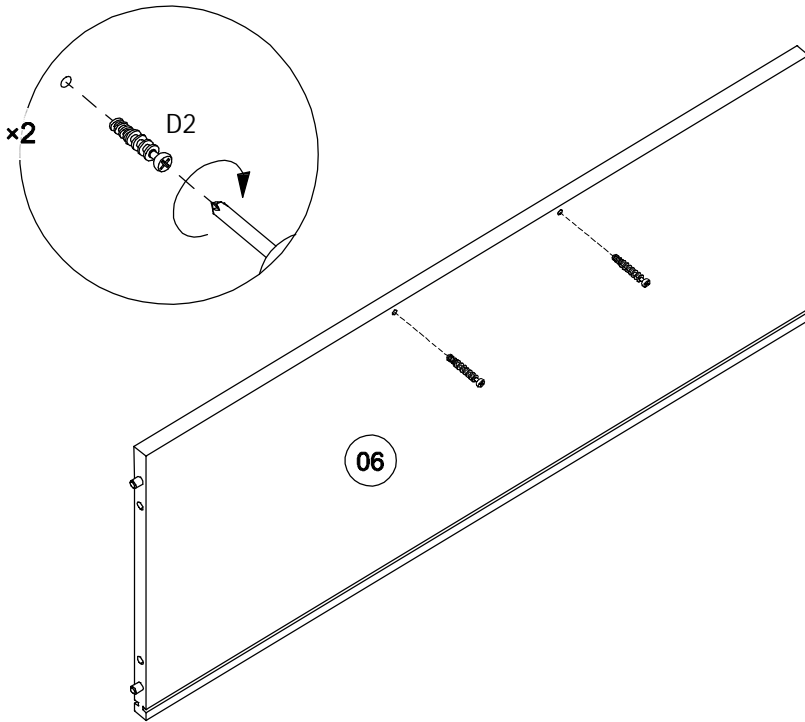

6

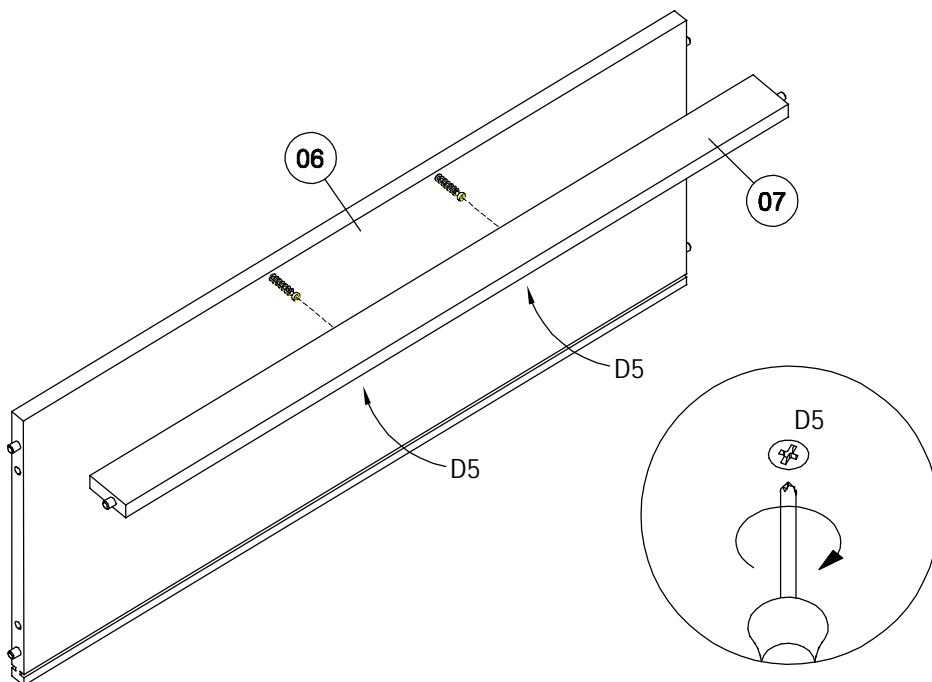
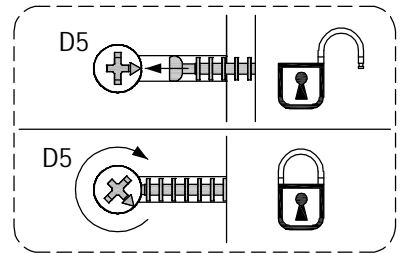



7

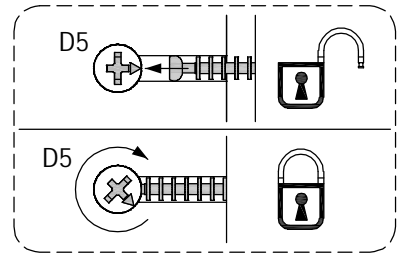
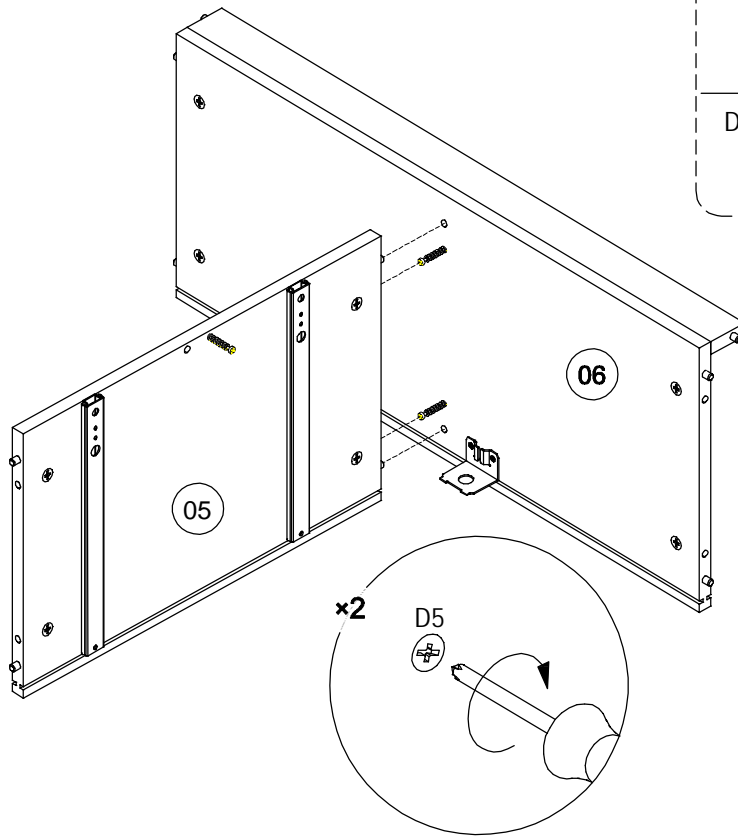

D4



$\times 2$

$\varnothing 17$

8

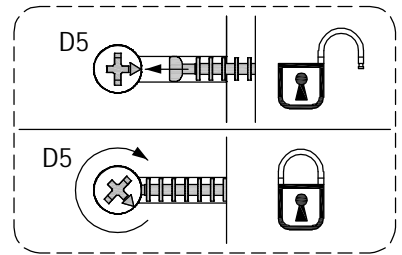
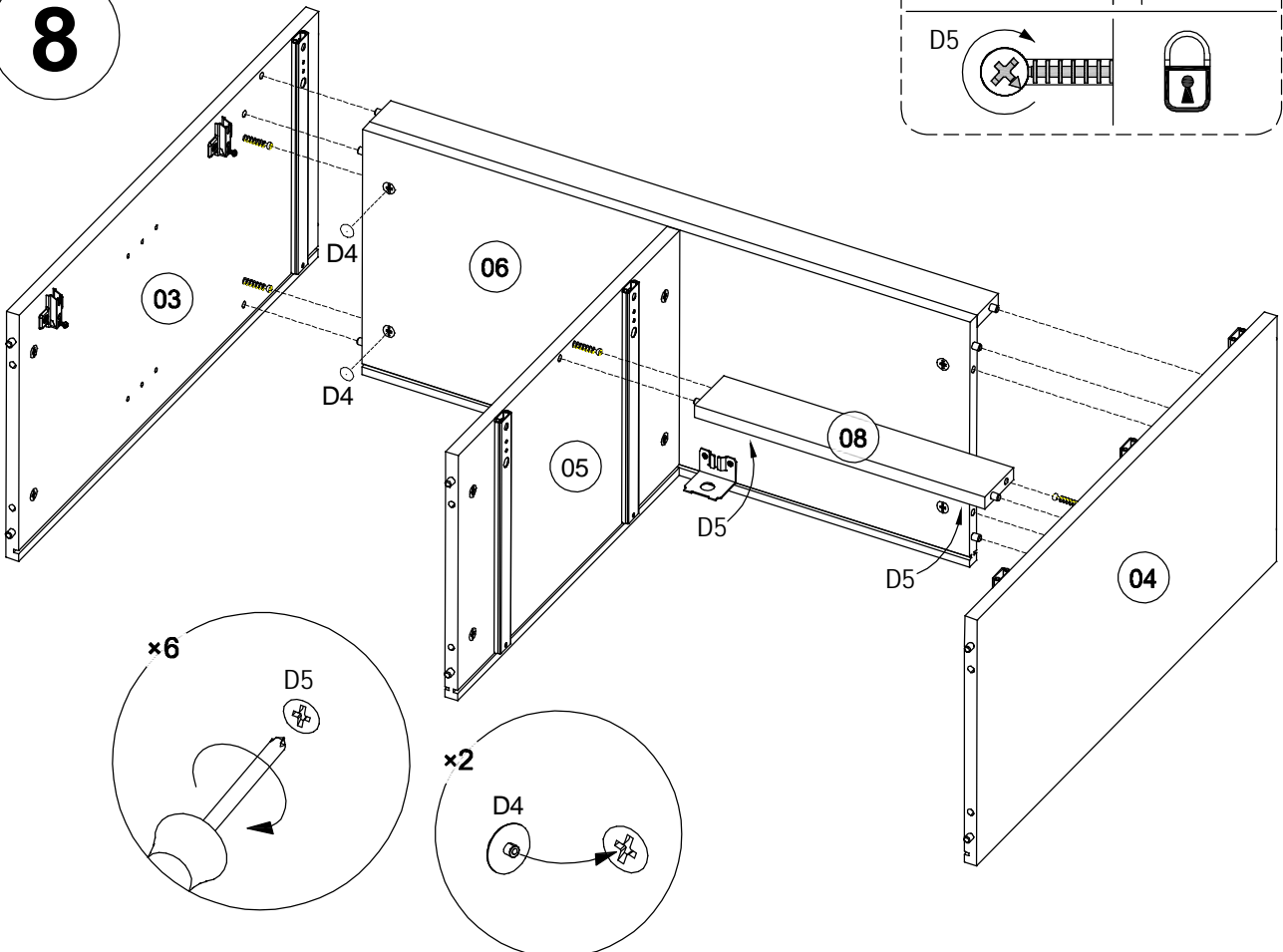

D4



x2

ø 17

9

D5

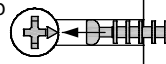

D5



x10

D5

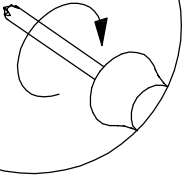

x2

D4

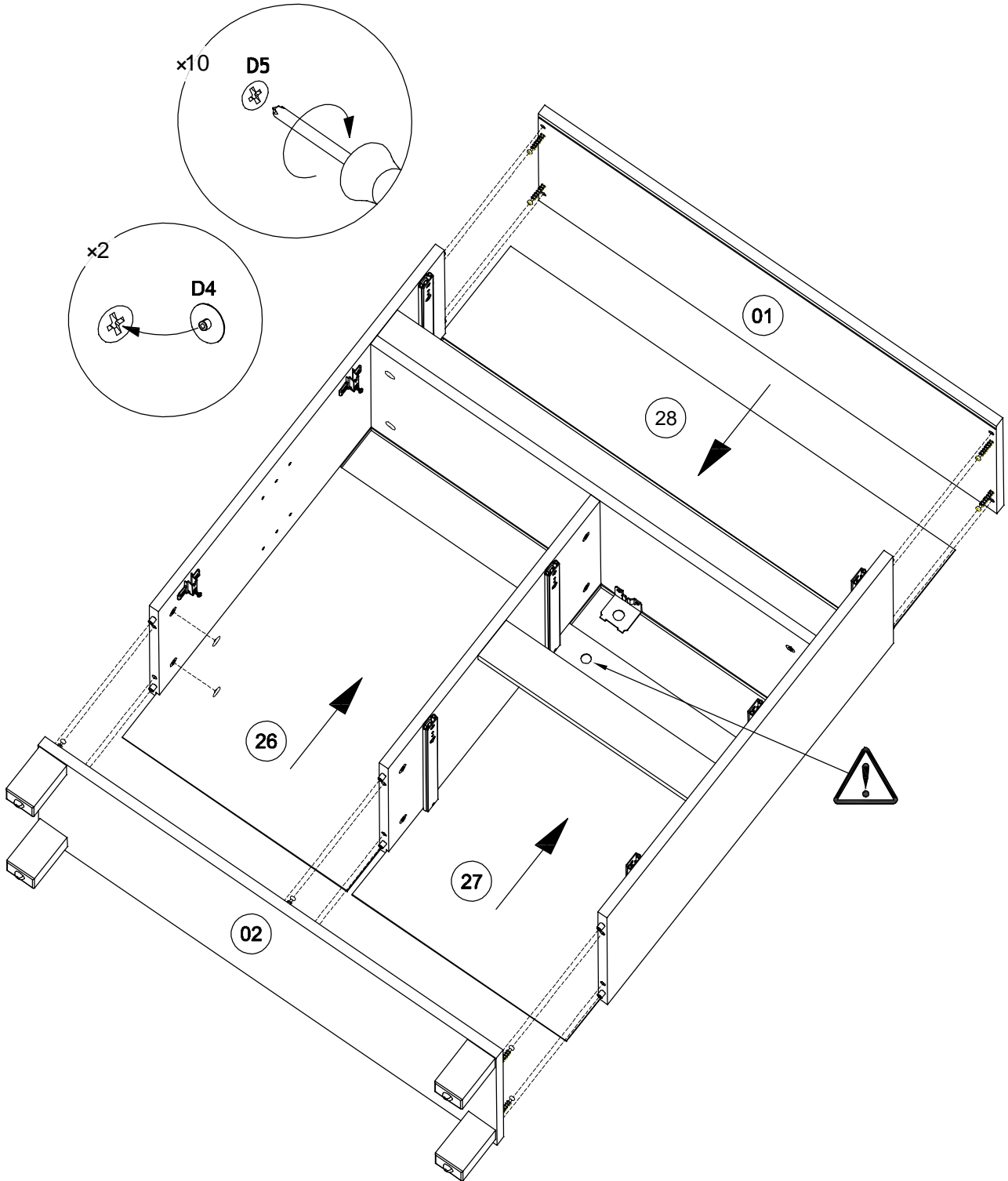

67632

D36 x14

**10**

90°

D31 x1

H8 x1

A69 x1

ø 6x35

ø 4x60

**11**

ø6mm

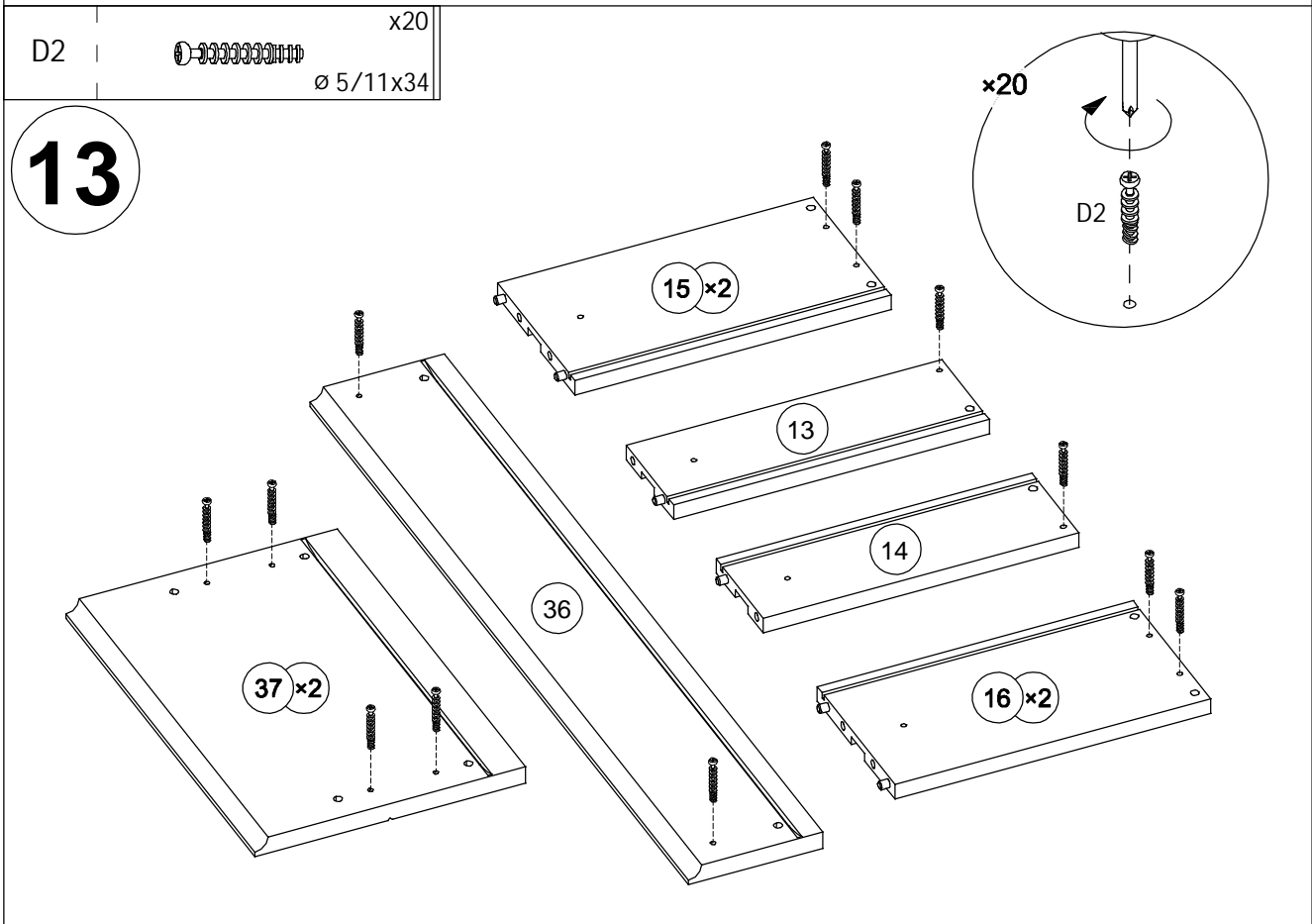
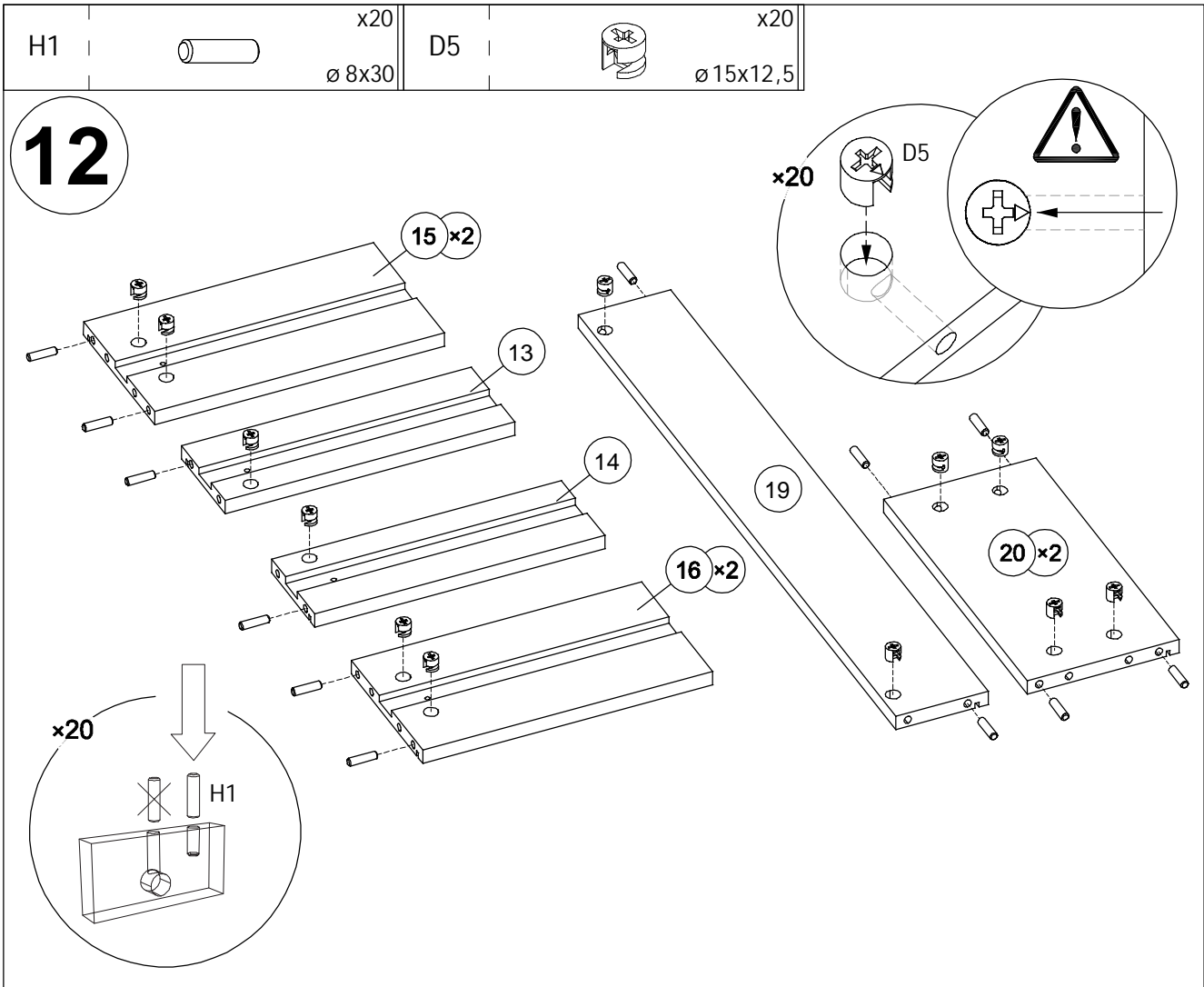

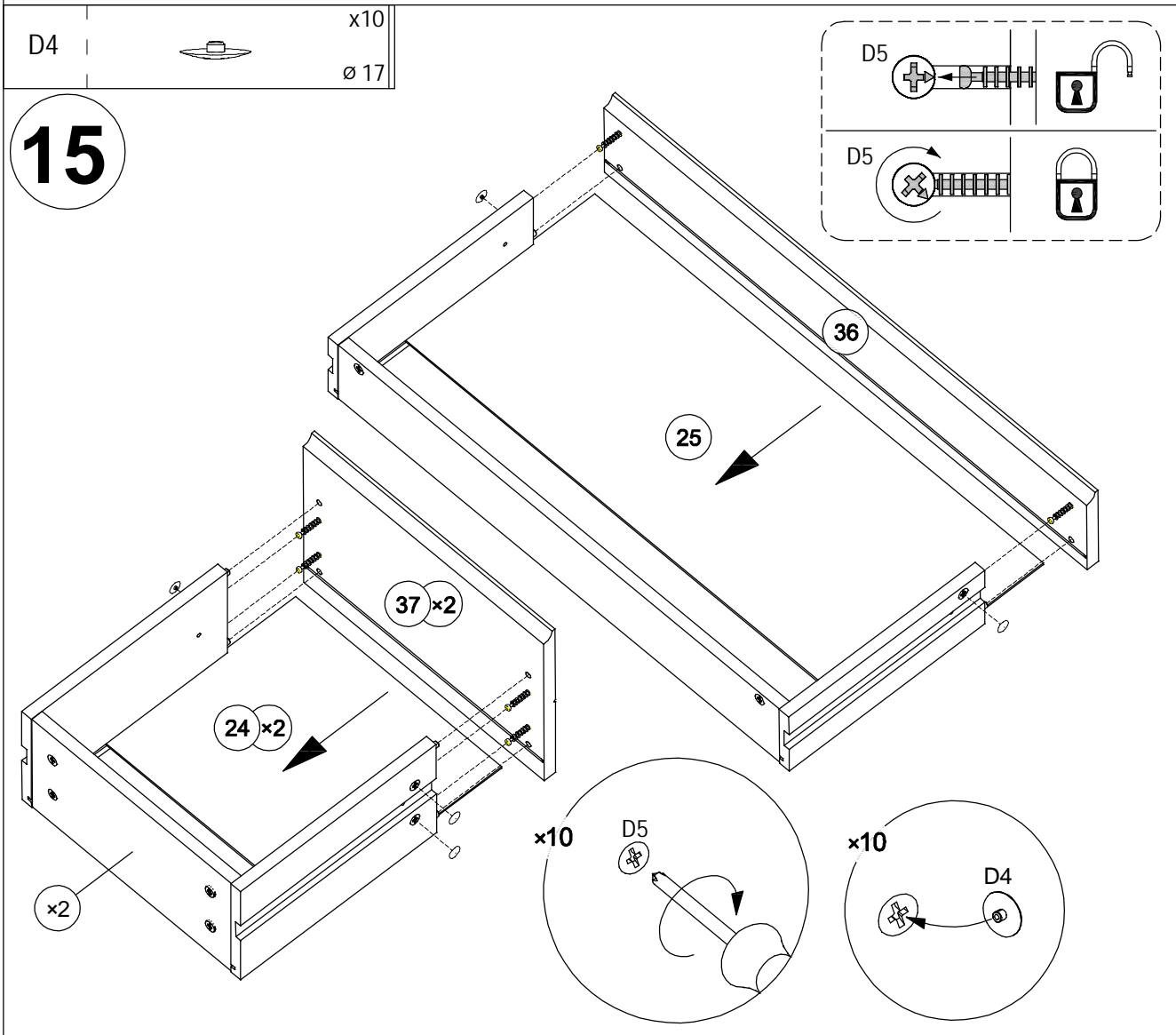
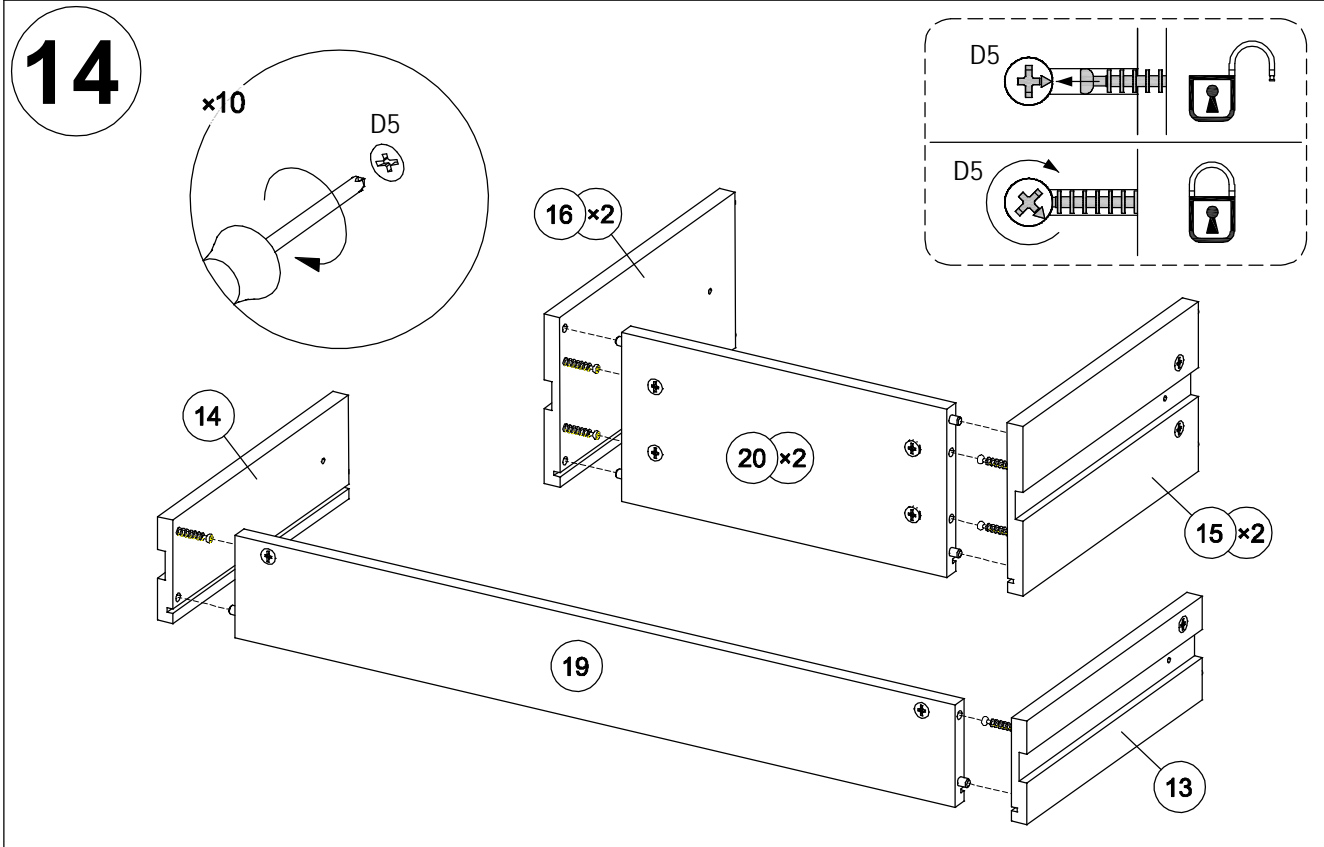

A8



x6

M4x12

16

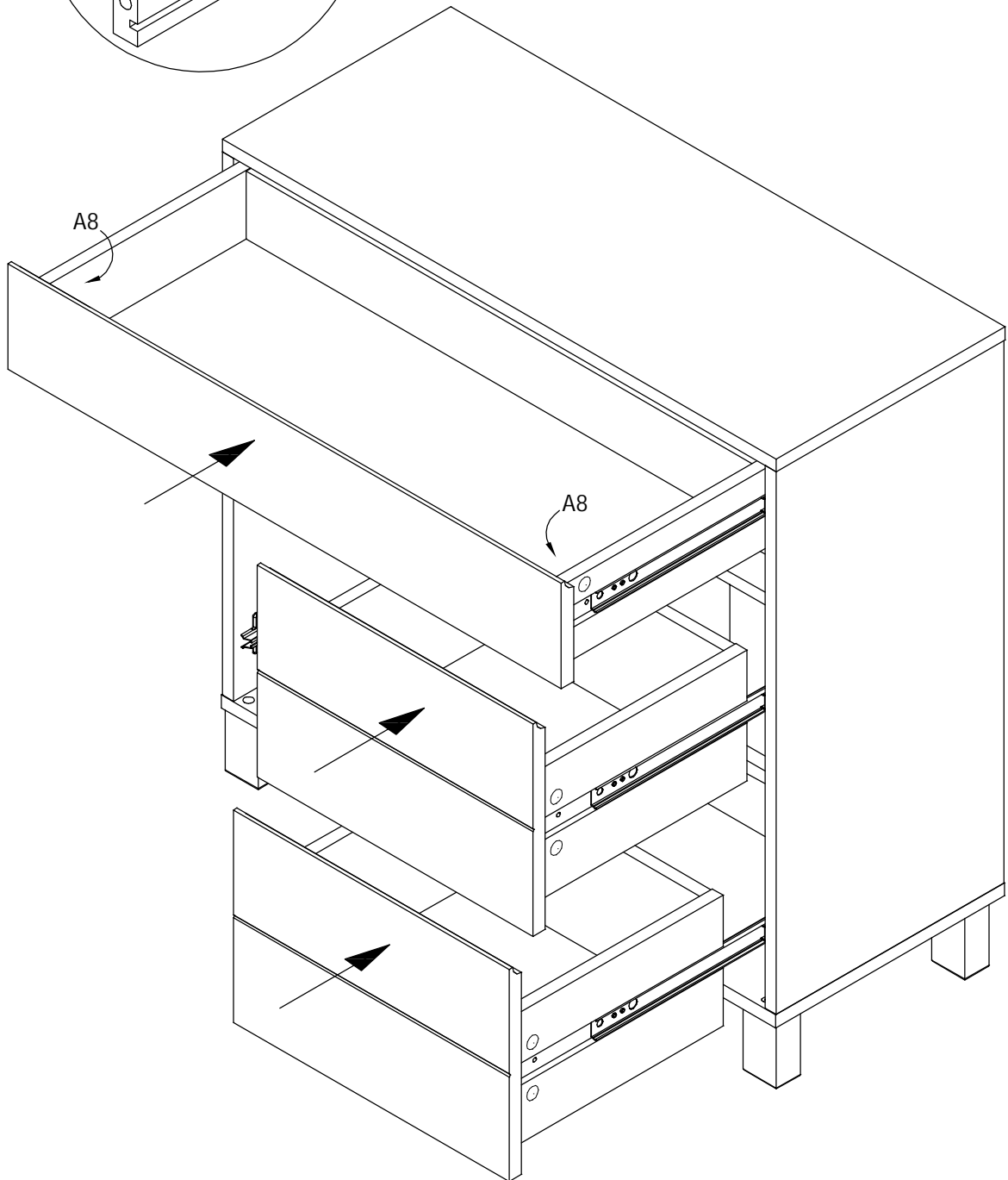
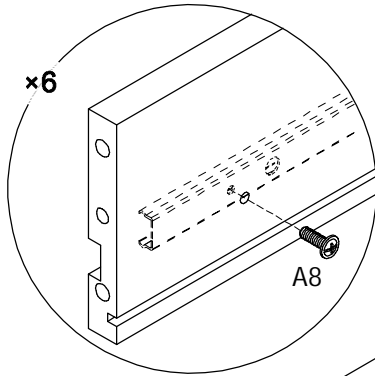

G39



x2  
ø 35

A1



x4  
ø 3,5x15

17

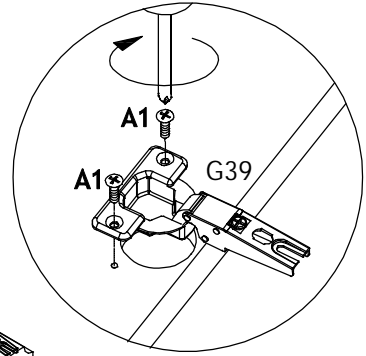
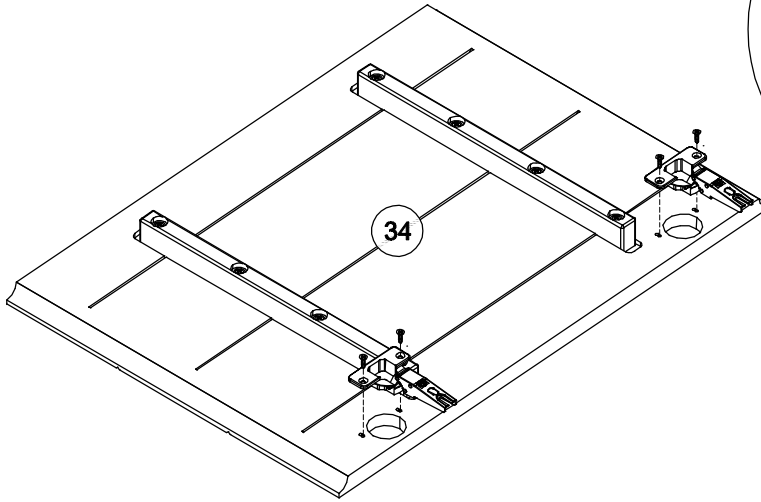

18

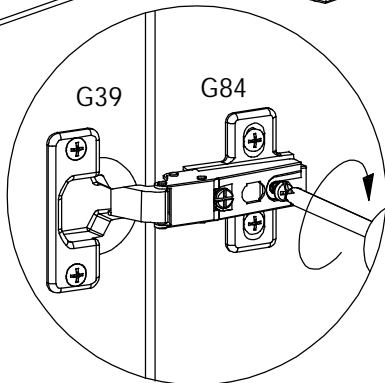
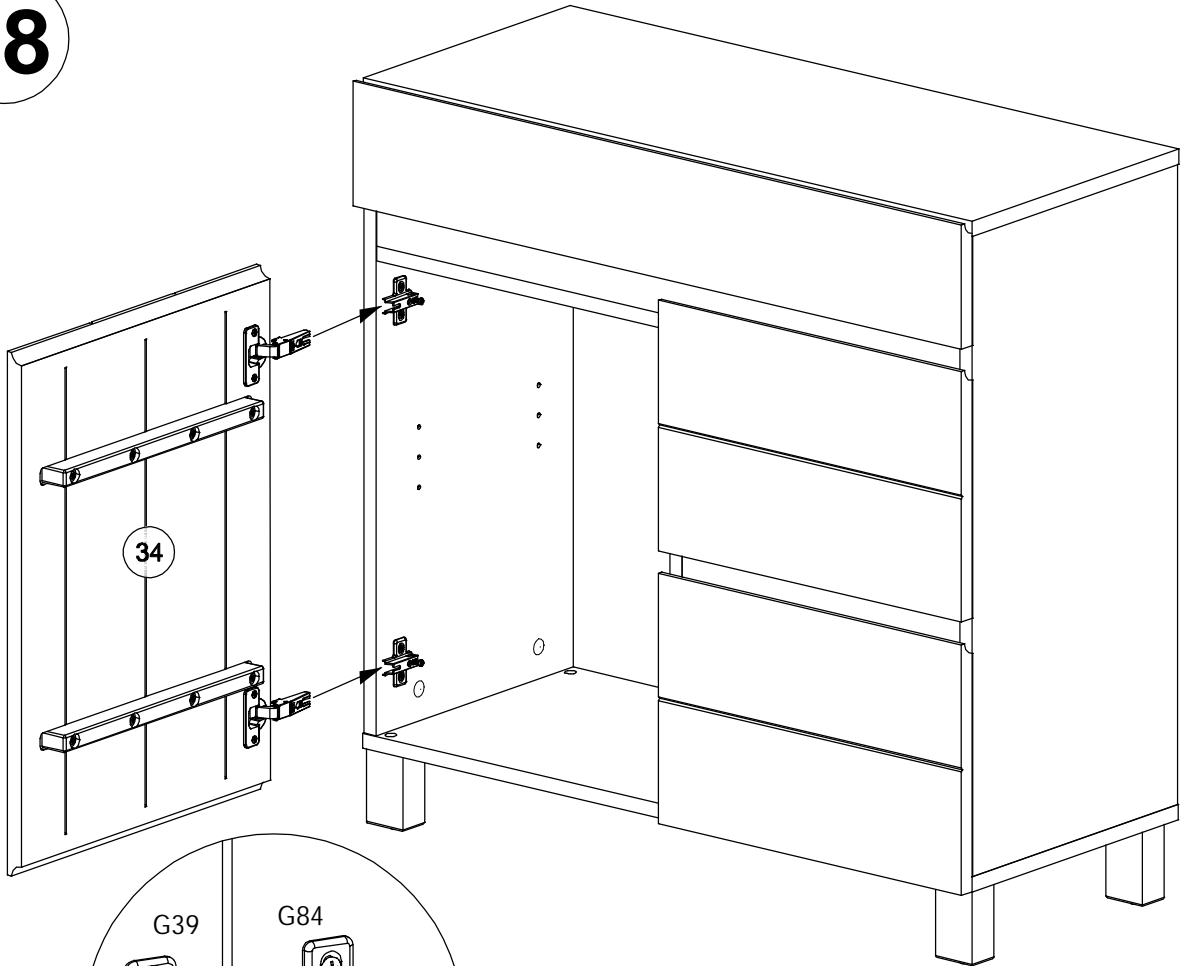

67632

D1



x4

19

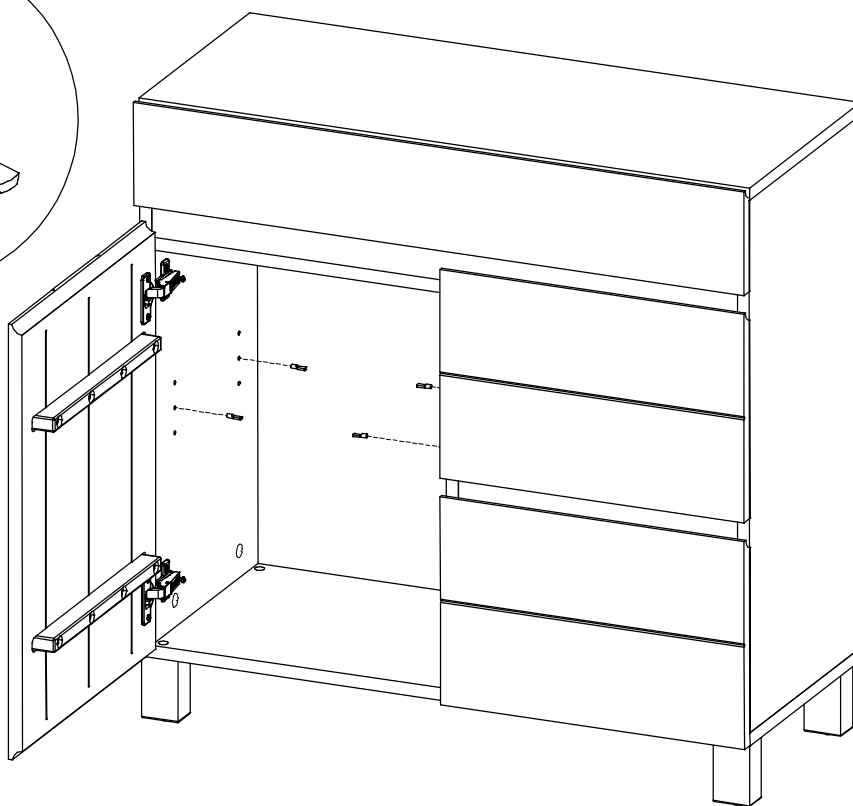
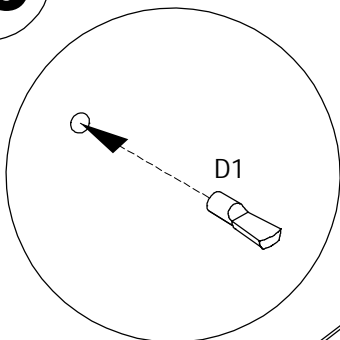

20

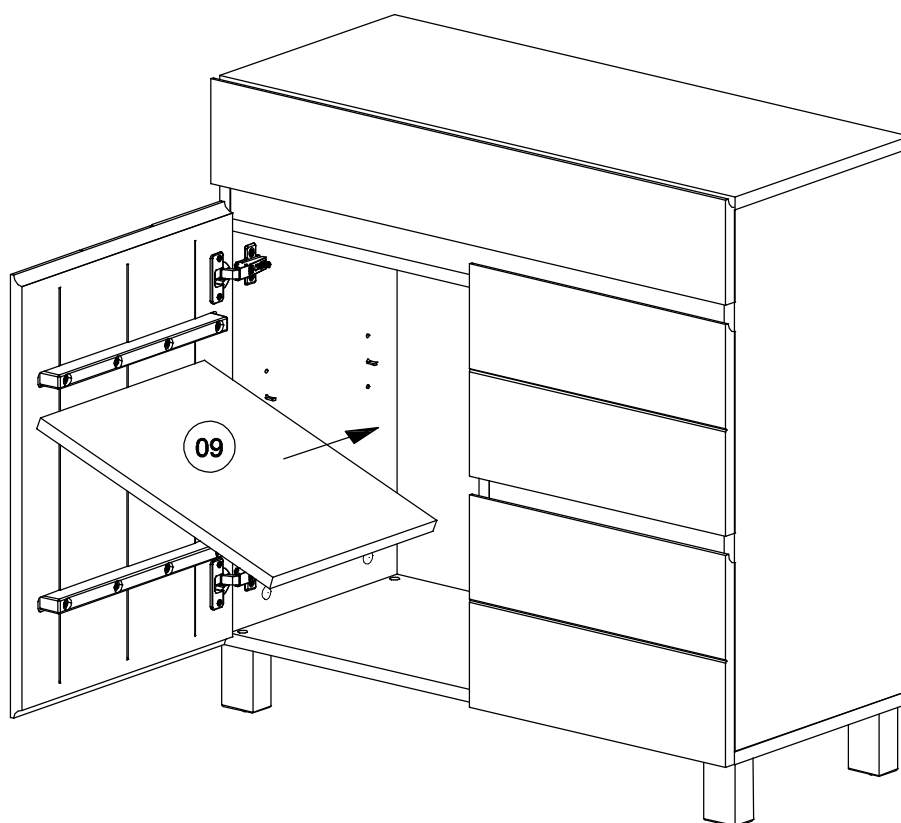



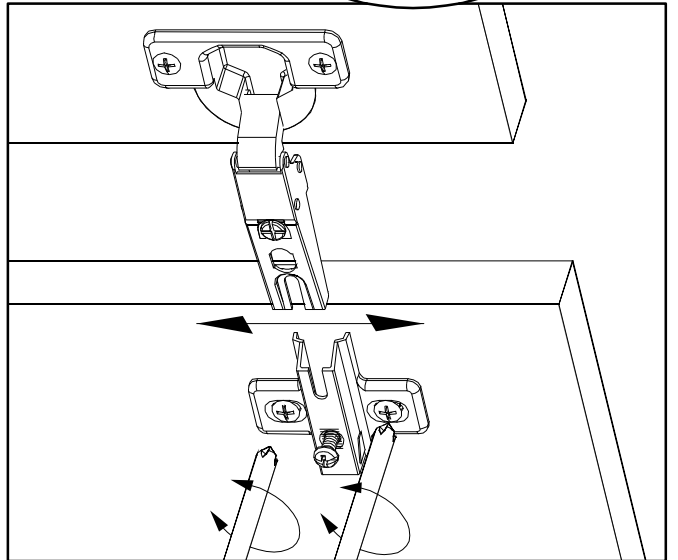
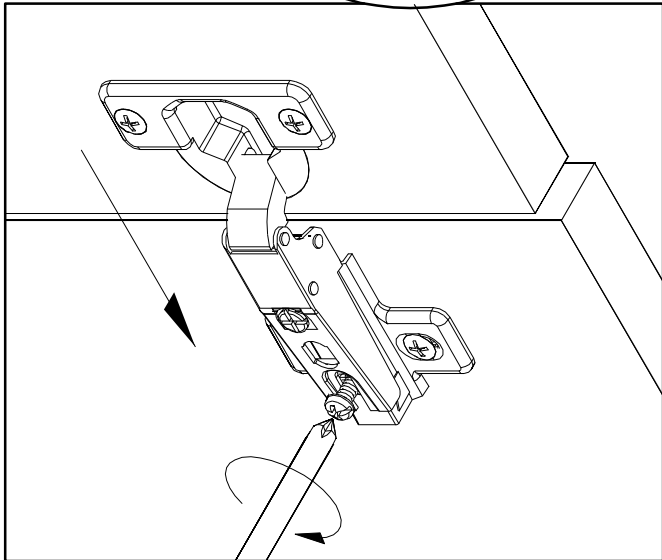
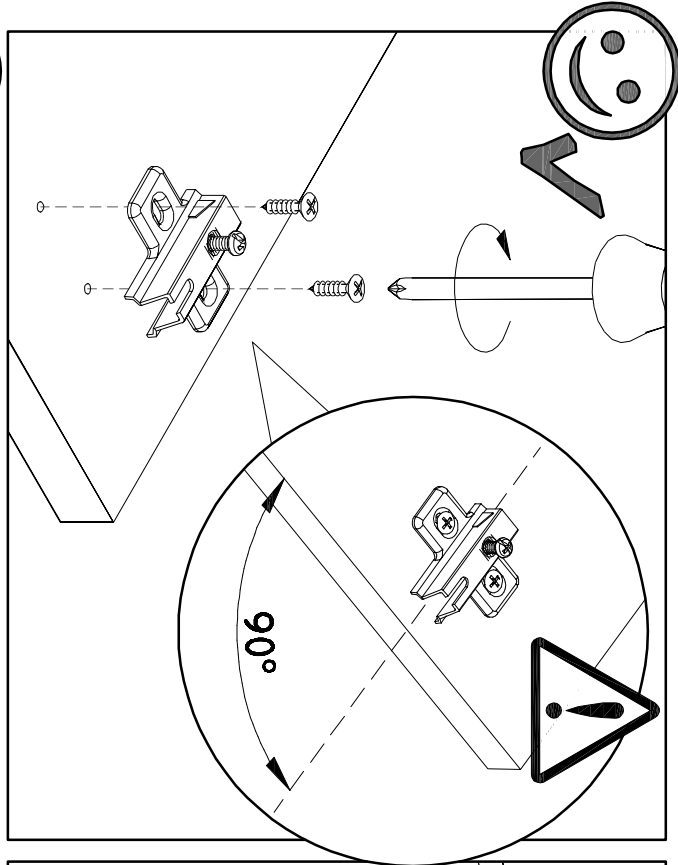
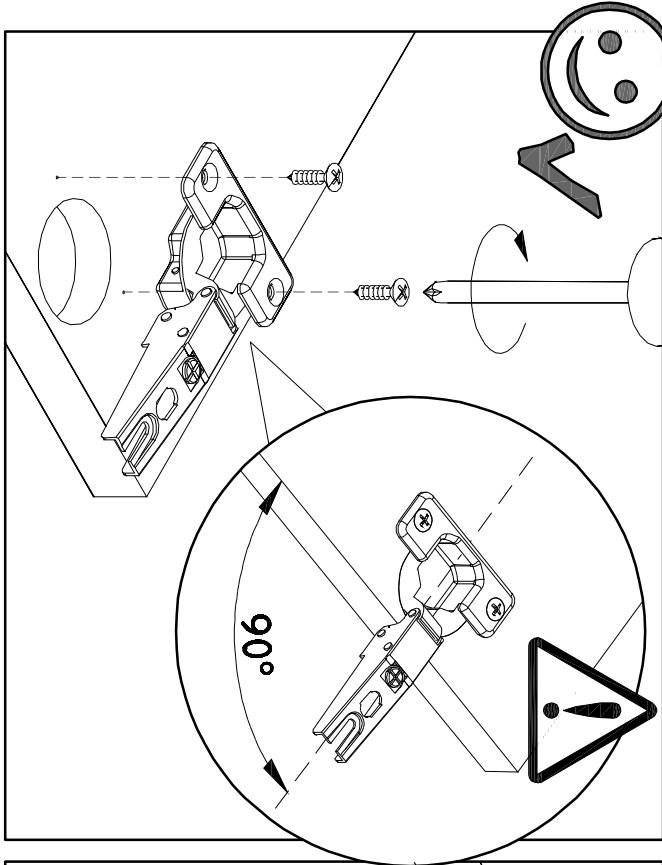
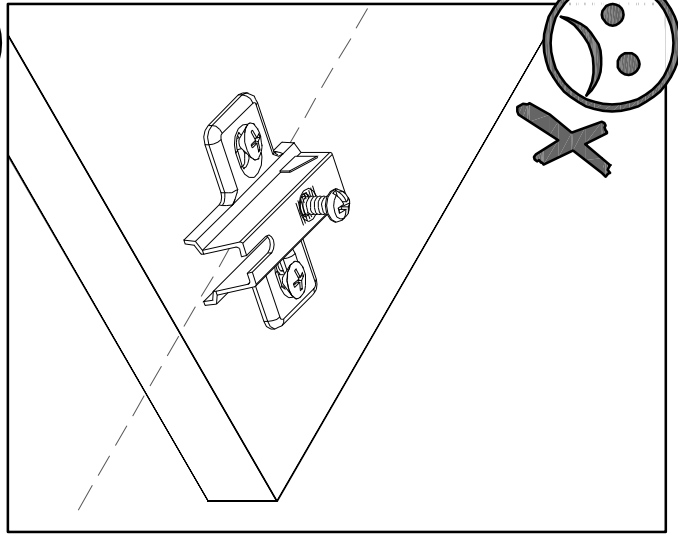
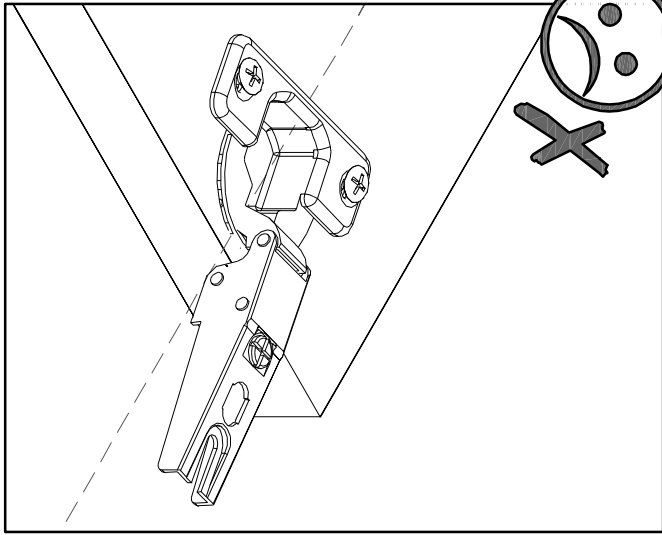

- (CZ) Úprava dveří  
 (D) Das Richten einer Türe  
 (F) Réglage d'une porte.  
 (HU) Beállítás egy ajtó  
 (I) Regolare una porta  
 (LV) Durvju regulēšana  
 (NL) Instellen van een deur  
 (PL) Regulacja drzwi  
 (RO) Reglarea o ușă  
 (RU) Регулировка Дверей  
 (SK) Úprava dverí  
 (TR) Bir kapı ayarlaması  
 (UK) Adjusting a door  
 (FIN) Oven säätö

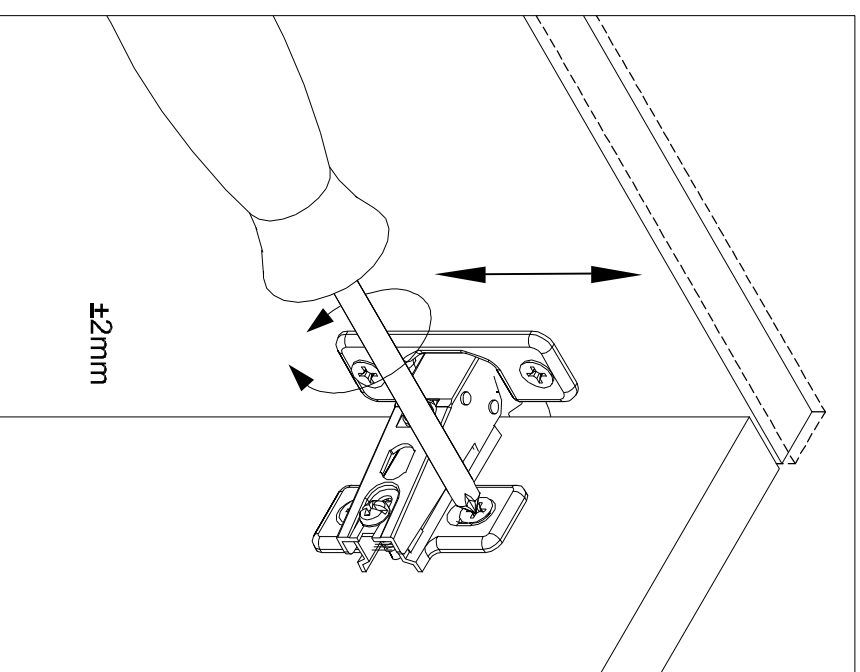
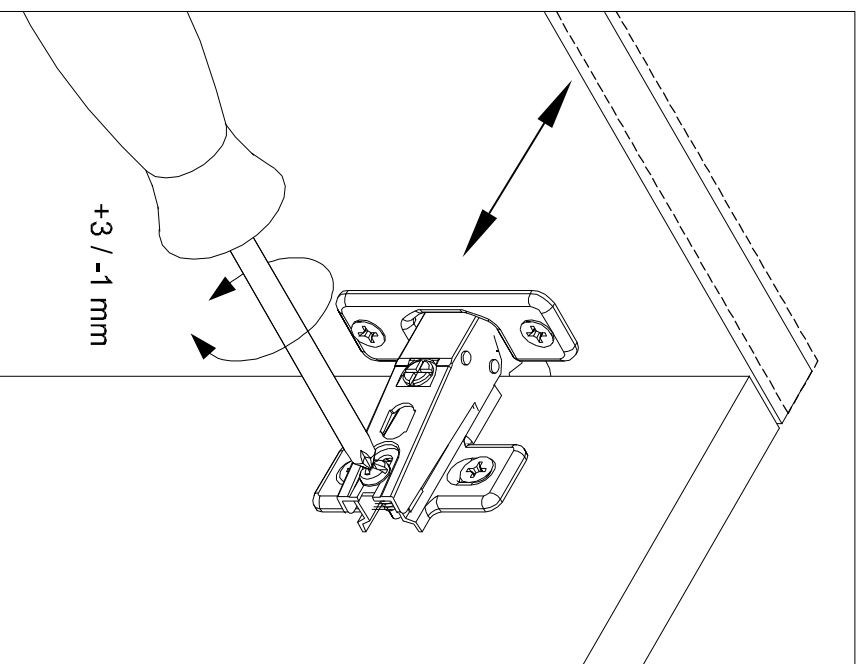
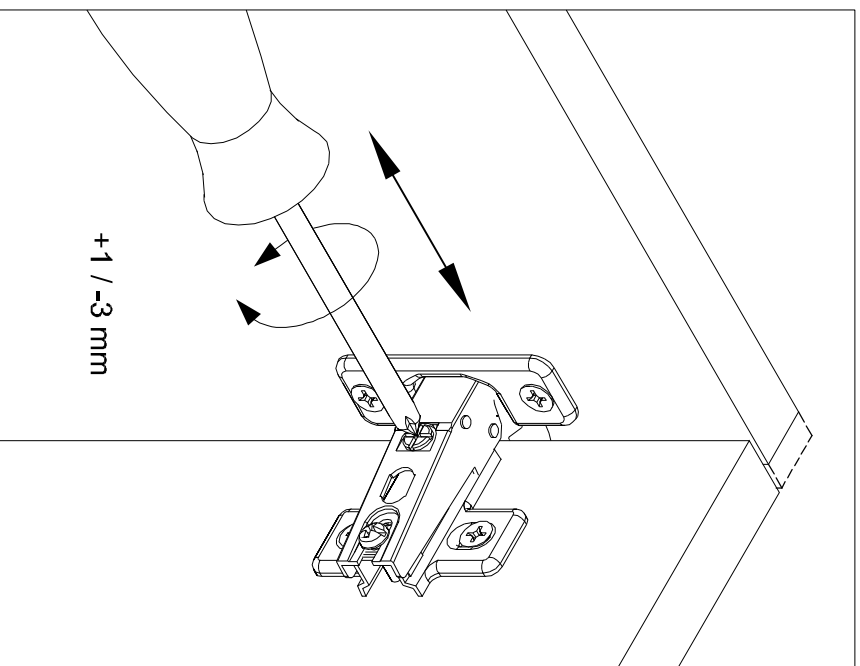

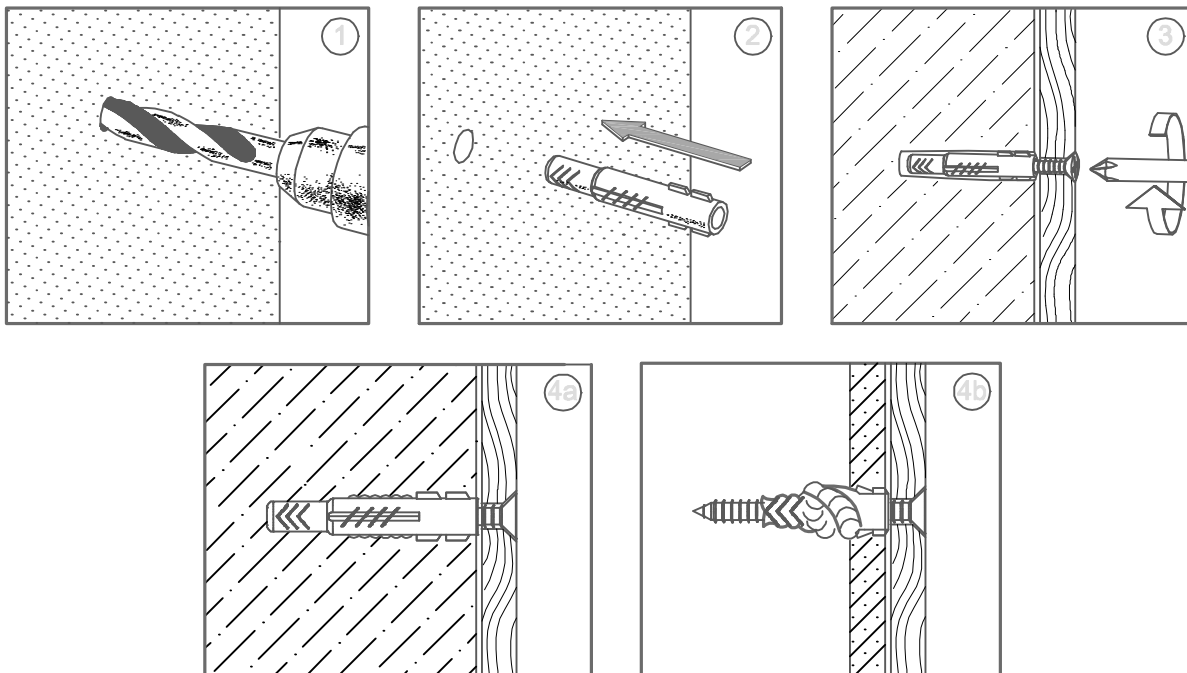
H8 A69   
ø4x60 ø6mm

- D** **Achtung:** Die Befestigung des Möbelstückes an der Wand muss von einer fachkundigen Person vorgenommen werden, da für die Montage an die Wand angepasste Dübel erforderlich sind.
- GB** **Attention:** A qualified professional is required when mounting furniture to the wall since dowels corresponding to the wall are required for this.
- FR** **Attention :** La fixation du meuble contre le mur doit être effectuée par une personne compétente car, pour le montage mural, il faut utiliser des chevilles adaptées.
- IT** **Attenzione:** Il fissaggio del mobile alla parete deve essere eseguito da persone esperte, dato che occorrono tasselli adeguati.
- NL** **Opgelet:** een vakkundige persoon dient het meubelstuk aan de muur te bevestigen; voor de montage aan de muur zijn immers aangepaste pluggen vereist.
- PL** **Uwaga:** Mocowanie mebla do ściany mogą przeprowadzić wyłącznie wykwalifikowane osoby, z uwagi na zastosowanie odpowiednio dopasowanych kołków do rodzaju ściany.
- CZ** **Pozor:** Montáž nábytku na stěnu musí provést odborník, protože k montáži na stěnu jsou zapotřebí upravené hmoždinky.
- SK** **Pozor:** Upevnenie nábytku na stenu musí vykonať odborník, nakoľko sú pre montáž na stenu potrebné vhodné hmoždinky.
- HU** **Figyelem:** A bútorelemek falra rögzítését szakembernek kell végeznie, mert a rögzítéshez megfelelő tiplít kell használni.
- RO** **Atenție:** Fixarea la perete a piesei de mobilier se realizează numai de către personal competent, deoarece montajul de perete necesită dibluri adecvate.
- TR** **Dikkat:** Mobilya parçasının duvara sabitlenmesi, duvar montajı için özel uyarlanmış dübeller gerektirdiğinden bu iş sadece bu konuda uzman bir kişi tarafından gerçekleştirilmelidir.
- RU** **Внимание:** Поскольку для монтажа на стене необходимо использовать специальные дюбели, мебель должна быть закреплена на стене квалифицированным персоналом.