

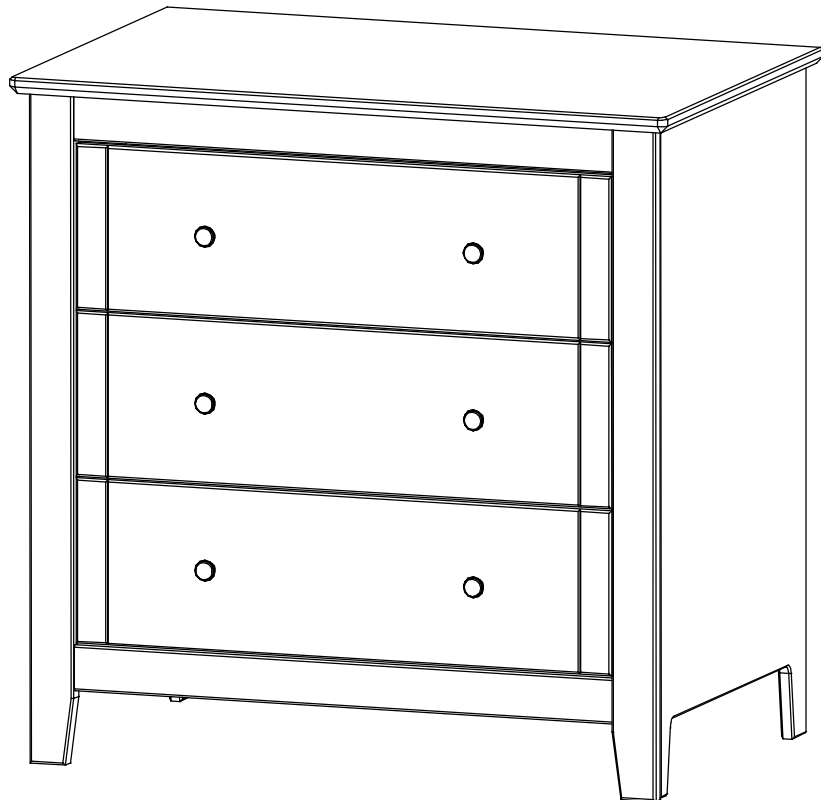

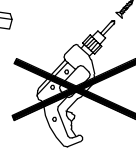

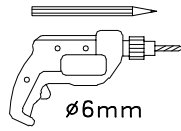

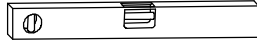

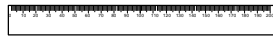
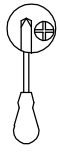
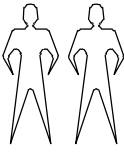
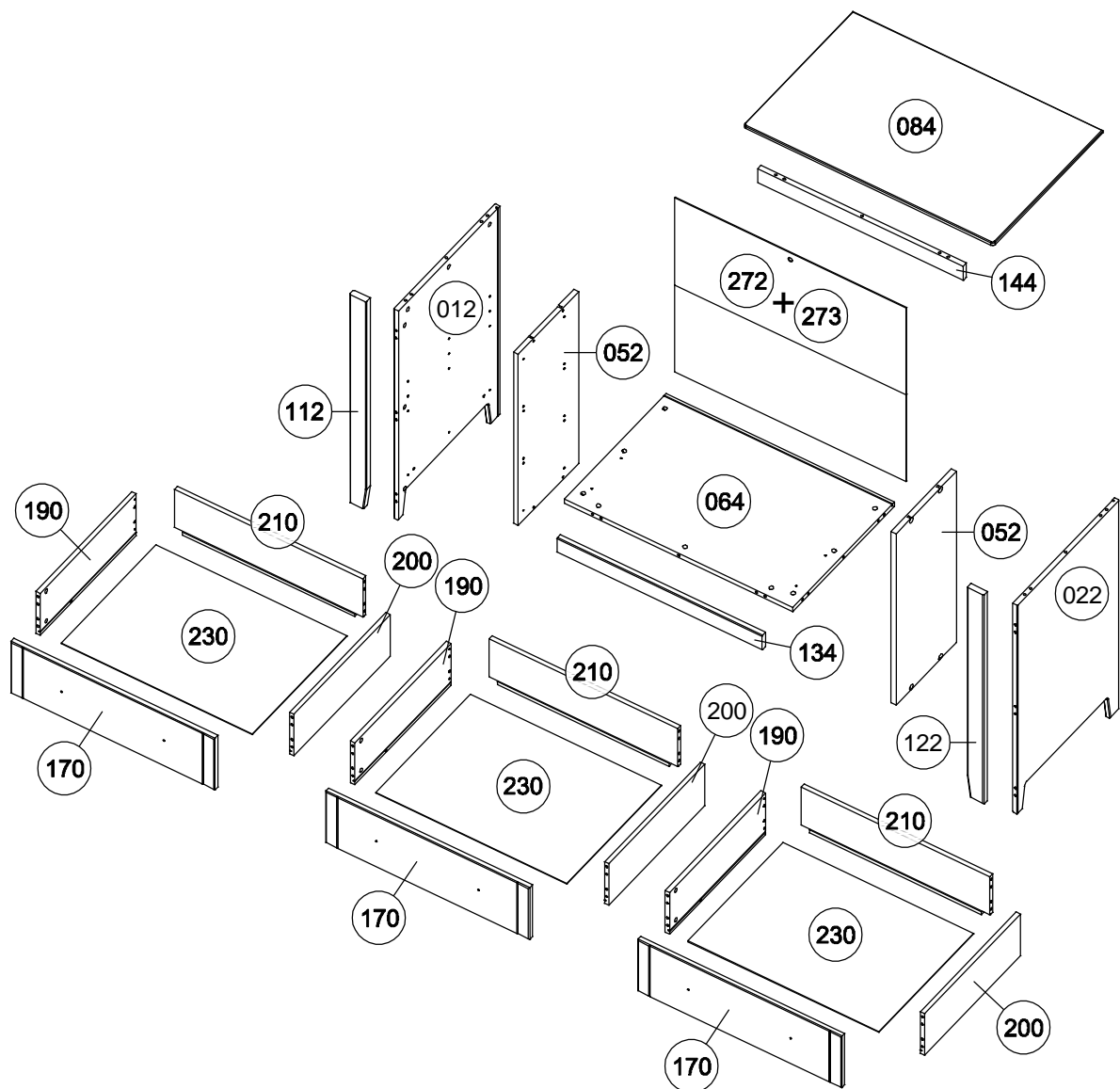





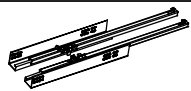

ROMEO II

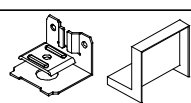

Teil Nr. Pièces Nr. Pieces Nr. Kārtas Nr.	Anzahl Quantité Quantity Skaitis	Kasten Nr. Colli Nr. Colli Nr. Kastes Nr.	Maß, mm Dimensions, mm Dimensions, mm Izmēri, mm	✓
012	1	1 / 2	900 x 556 x 18	
022	1	1 / 2	900 x 556 x 18	
052	2	2 / 2	738 x 330 x 18	
064	1	2 / 2	846 x 556 x 18	
084	1	2 / 2	928 x 600 x 22	
112	1	1 / 2	900 x 62 x 22	
122	1	1 / 2	900 x 62 x 22	
134	1	2 / 2	760 x 62 x 18	
144	1	2 / 2	760 x 62 x 18	
170	3	1 / 2	756 x 222 x 18	
190	3	2 / 2	525 x 180 x 16	
200	3	2 / 2	525 x 180 x 16	
210	3	2 / 2	698 x 180 x 16	
230	3	1 / 2	707 x 518 x 3	
272+273	1	1 / 2	857 x 748 x 3	

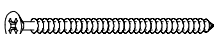

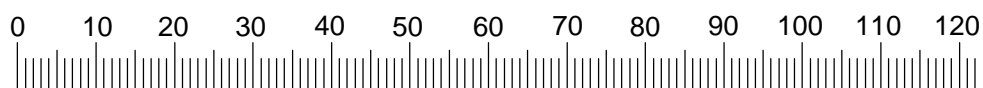

H1		x42 ø 8x30	D2		x48 ø 5/11x34	D3		x24 ø 15x13,8
D20		x8	D4		x12 ø 17	D5		x24 ø 15x12,5
D19		x8 11 mm	E107		x3 535 mm	A36		x12 ø 6x10,5
D206		x4 ø 15	B100		x6 ø 28x20	A3		x6 M4x23
D31		x1	H8		x1 ø 6x35	A69		x1 ø 4x60
						A1		x14 ø 3,5x15

- D** Sehr geehrter Kunde, hier haben Sie die Möglichkeit mitgelieferte Schrauben nachzumessen.
- UK** Dear customer. Here you have the possibility of measuring the supplied screws.
- FR** Cher client, Ici vous avez la possibilité de mesurer les vis livrees.
- LV** Godātais pircēj, šeit Jums ir iespēja izmērīt pievienotās skrūves.

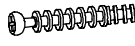

67254

D2	 x15 ø 5/11x34	D19	 x4 11 mm
----	--	-----	---

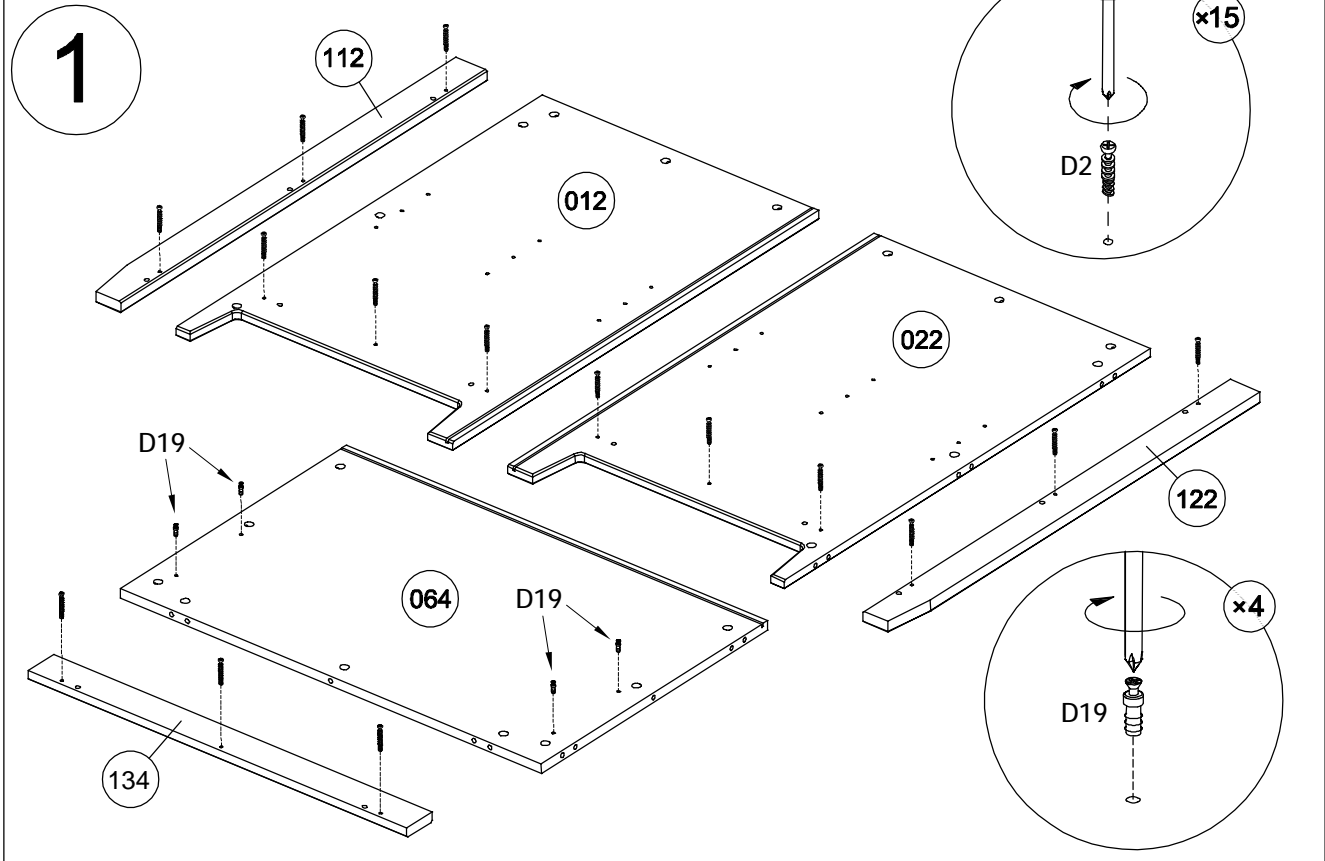

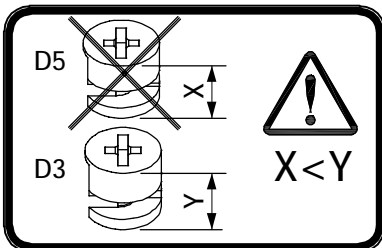
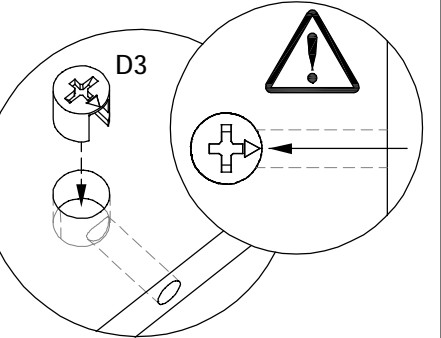

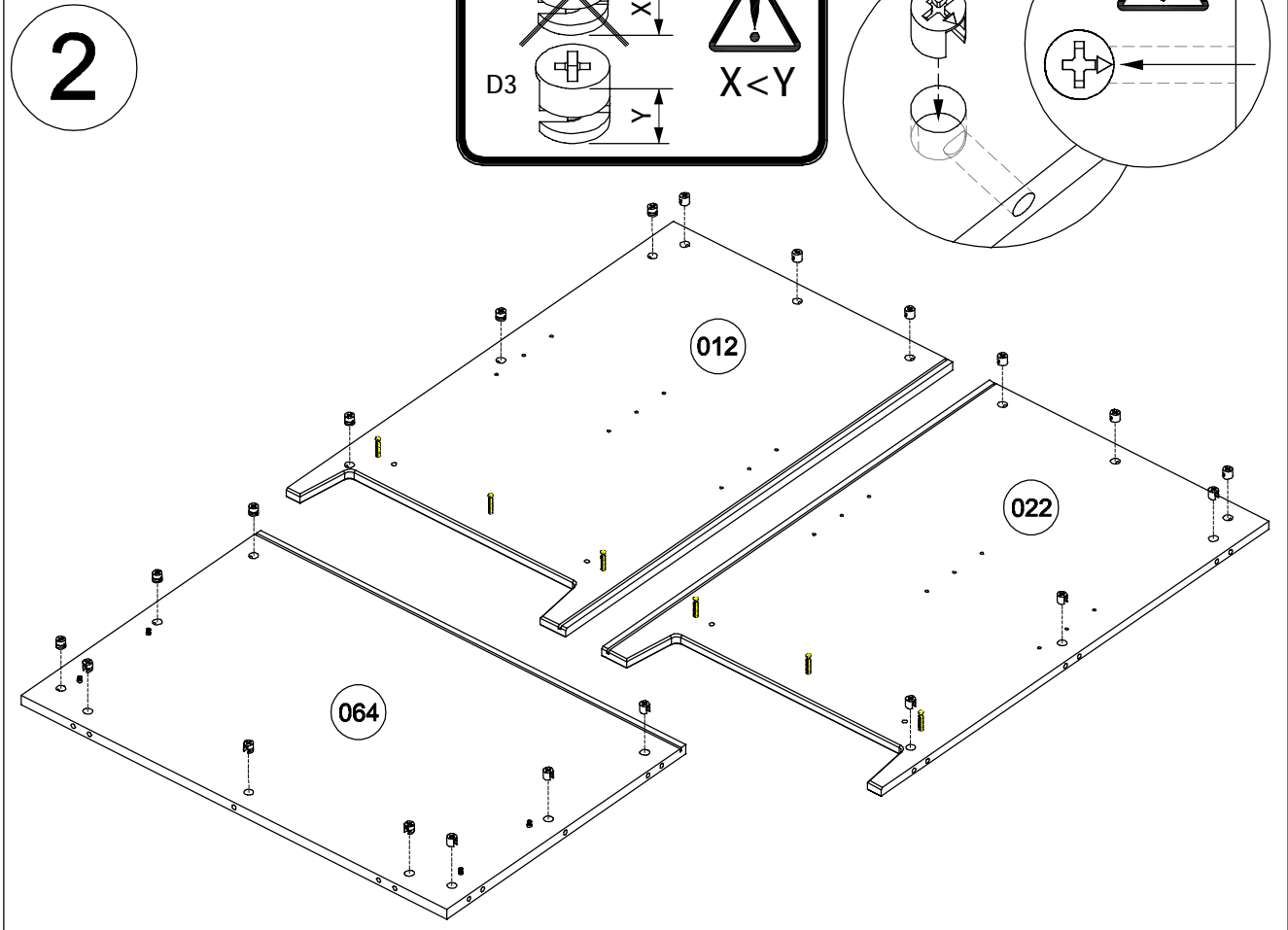
D3	 x21 ø 15x13,8		
----	--	---	---

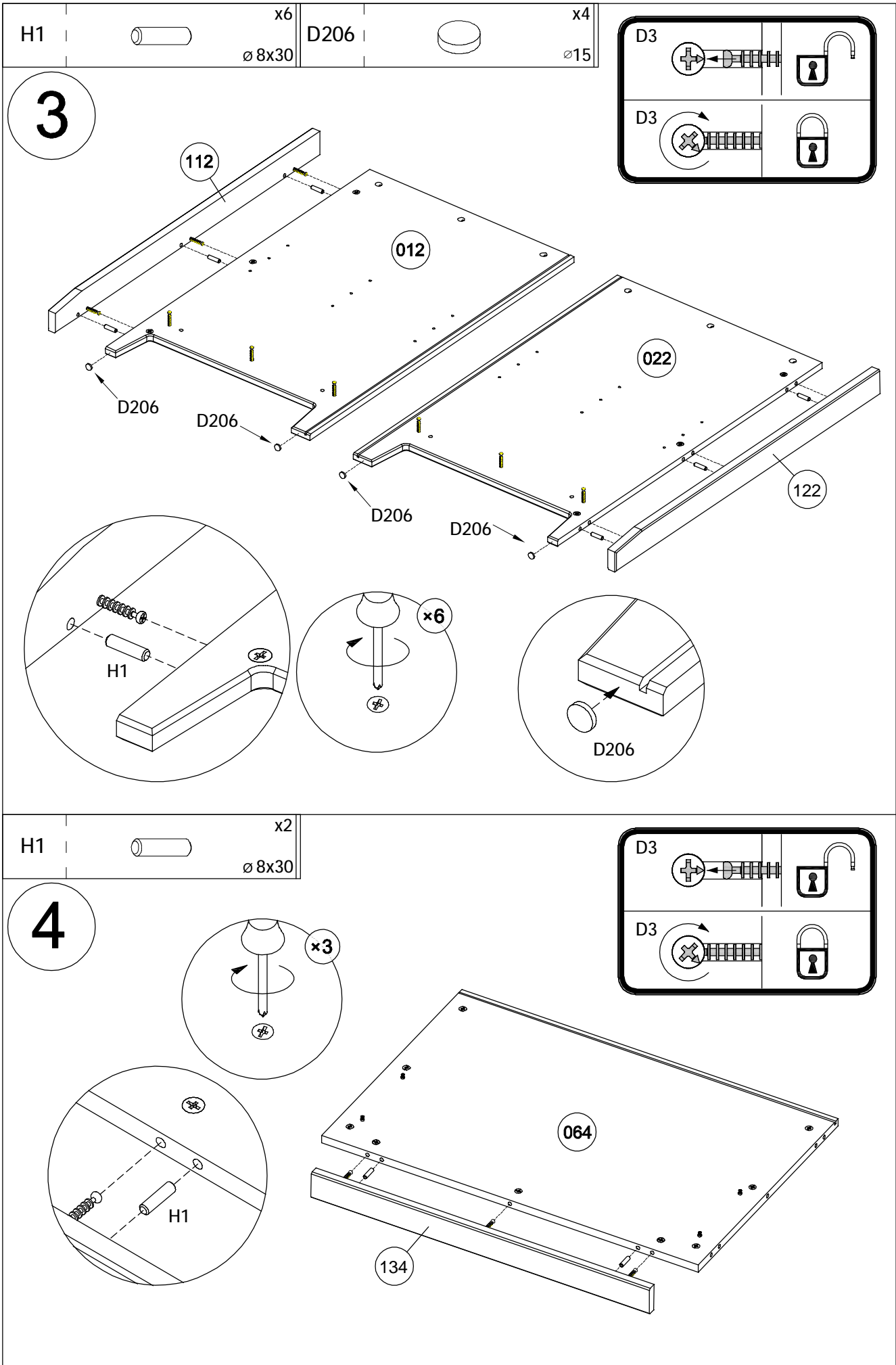

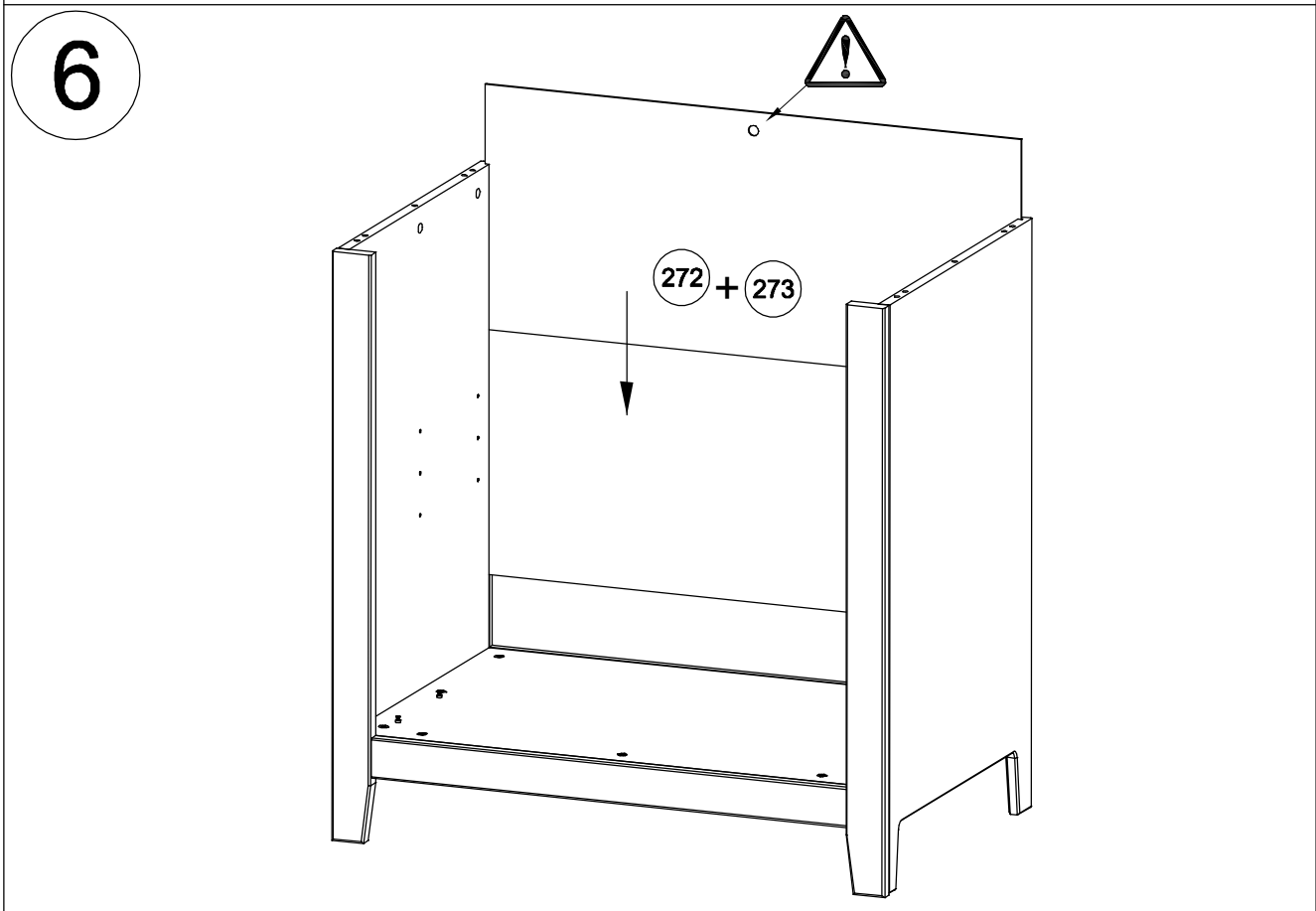
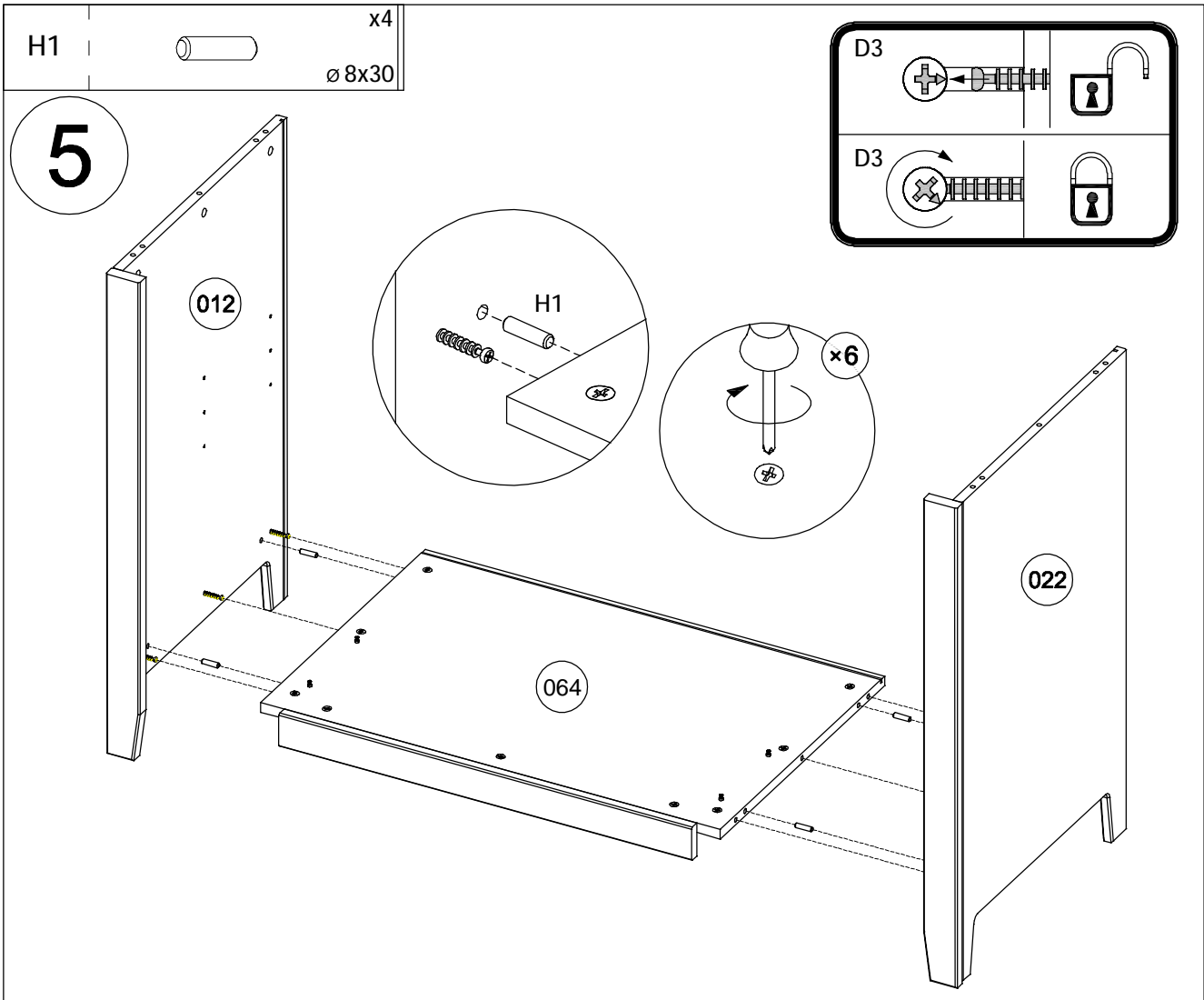

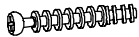
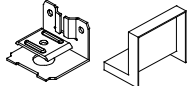

D2	 x9 ø 5/11x34	D31	 x1	A1	 x2 ø 3,5x15
----	---	-----	--	----	--

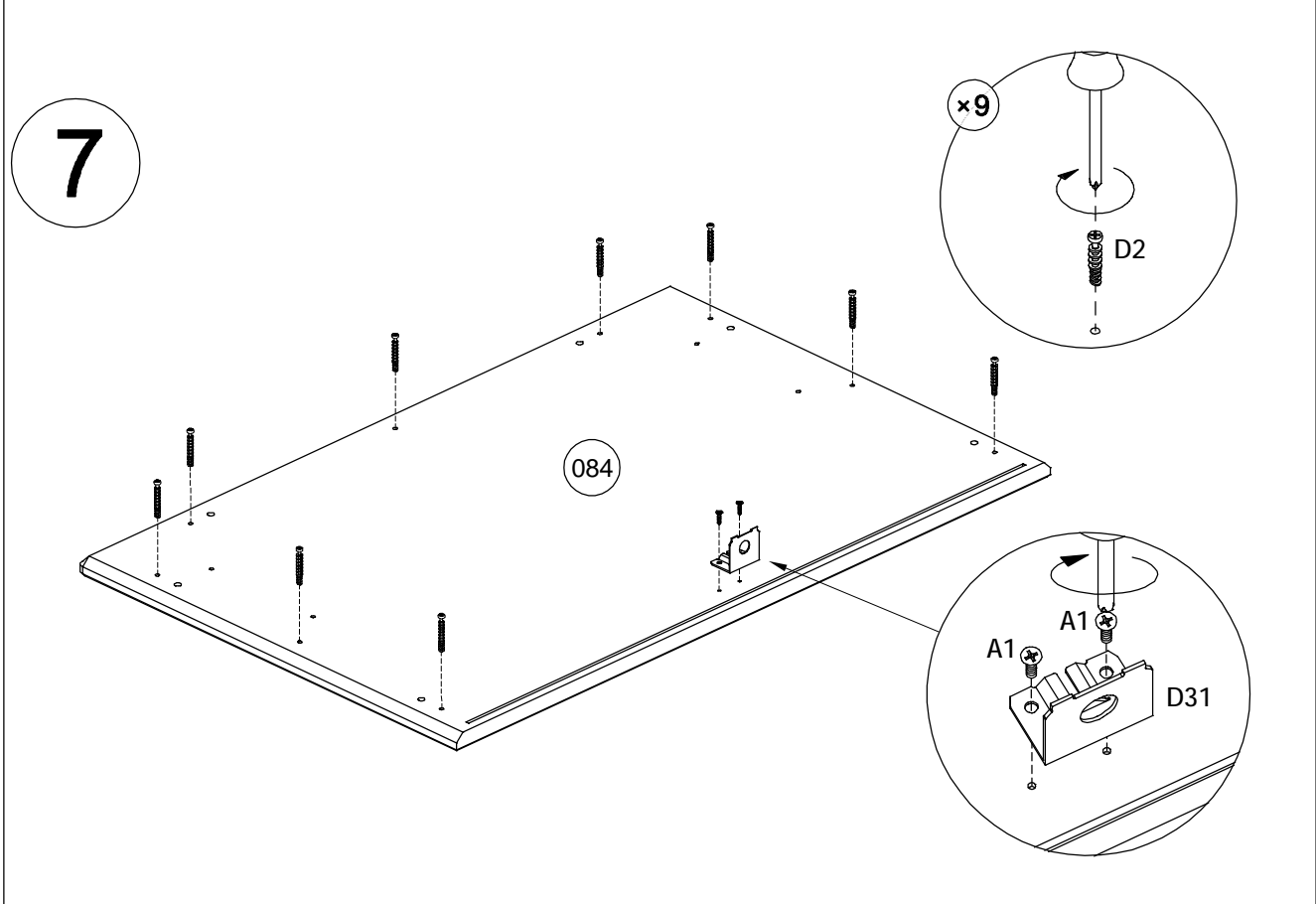

D19	 x4 11 mm
-----	---

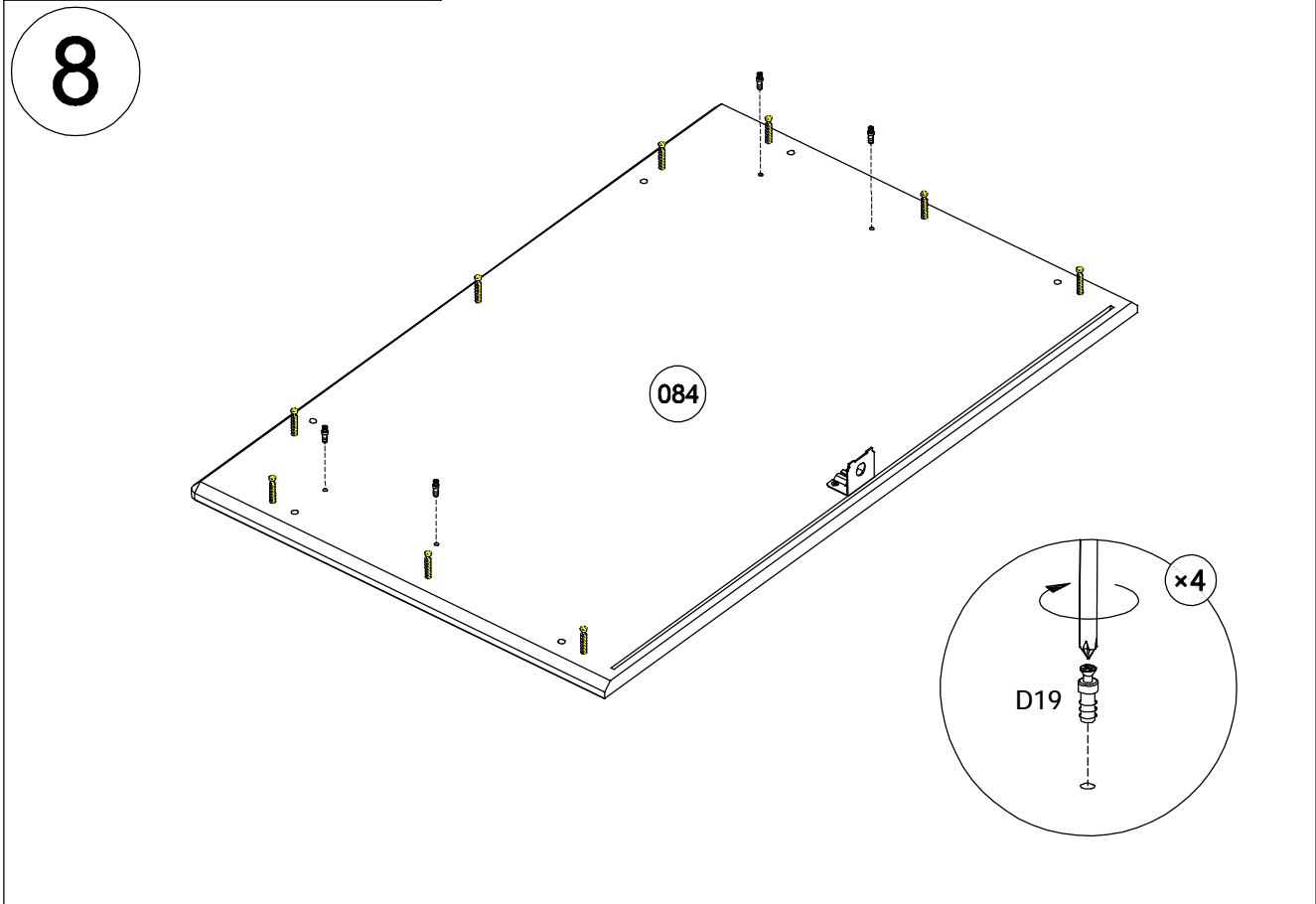

D3 x3
ø 15x13,8

9

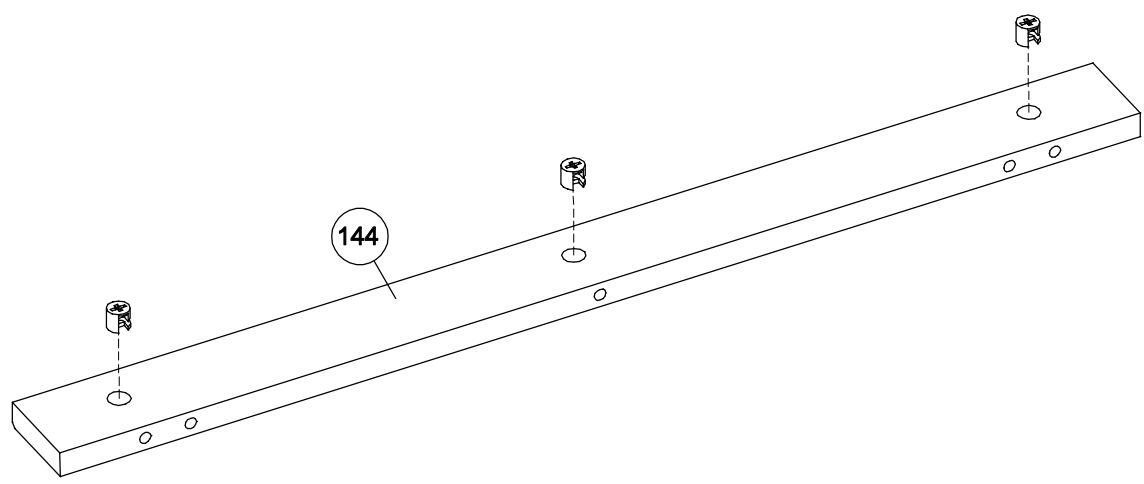
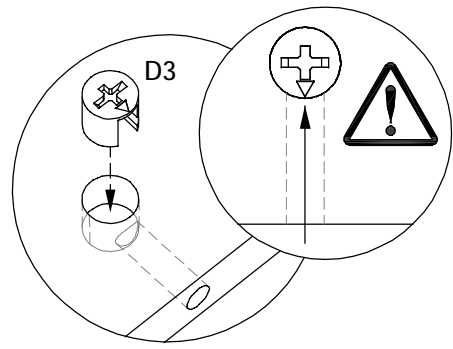
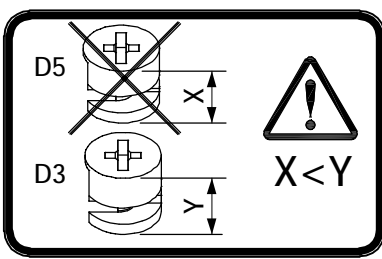

H1 x2
ø 8x30

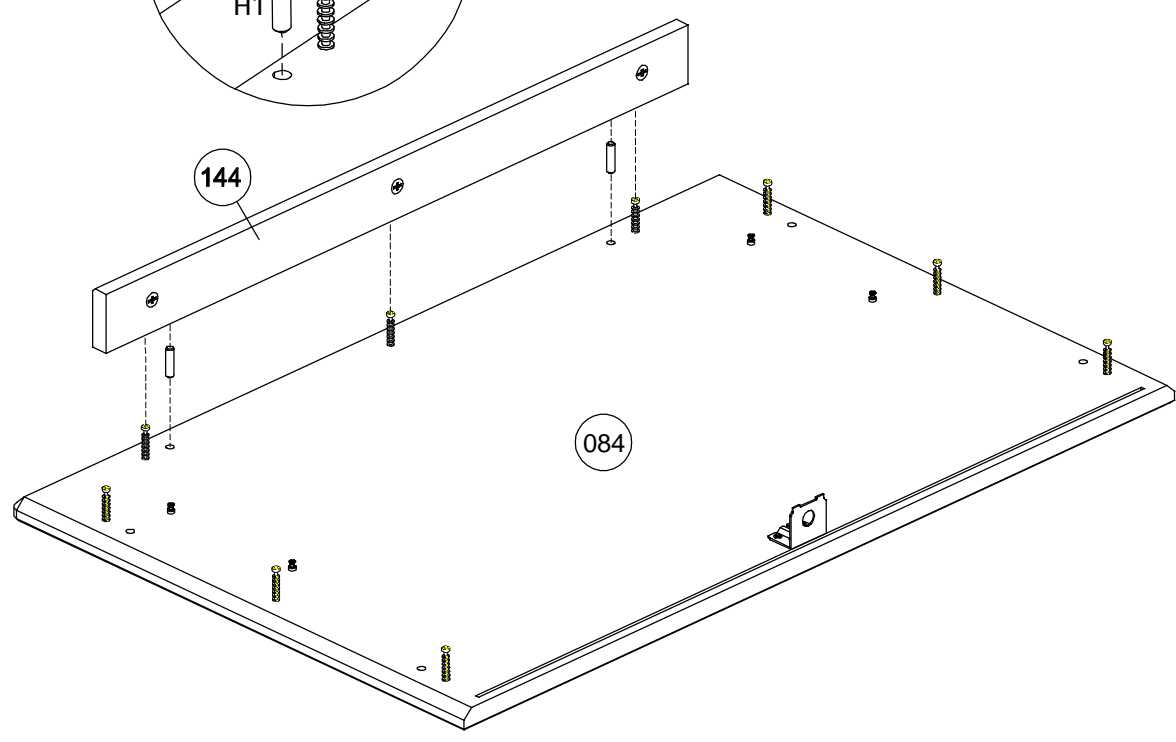
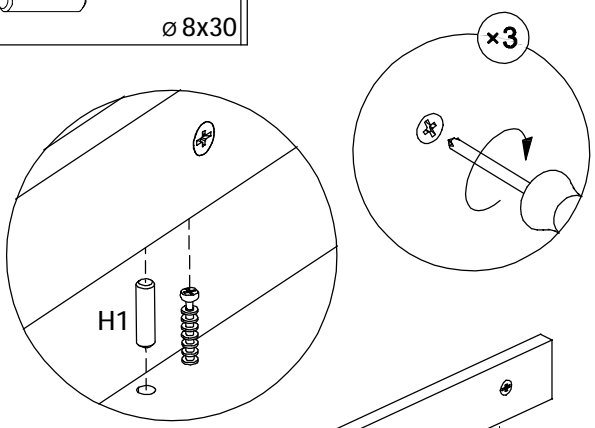
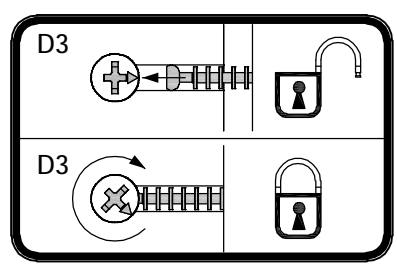

10

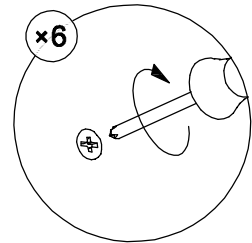
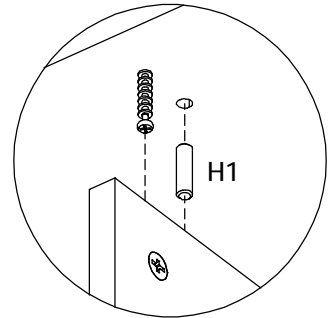
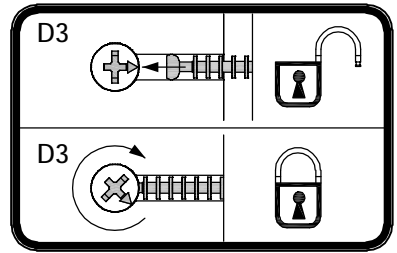
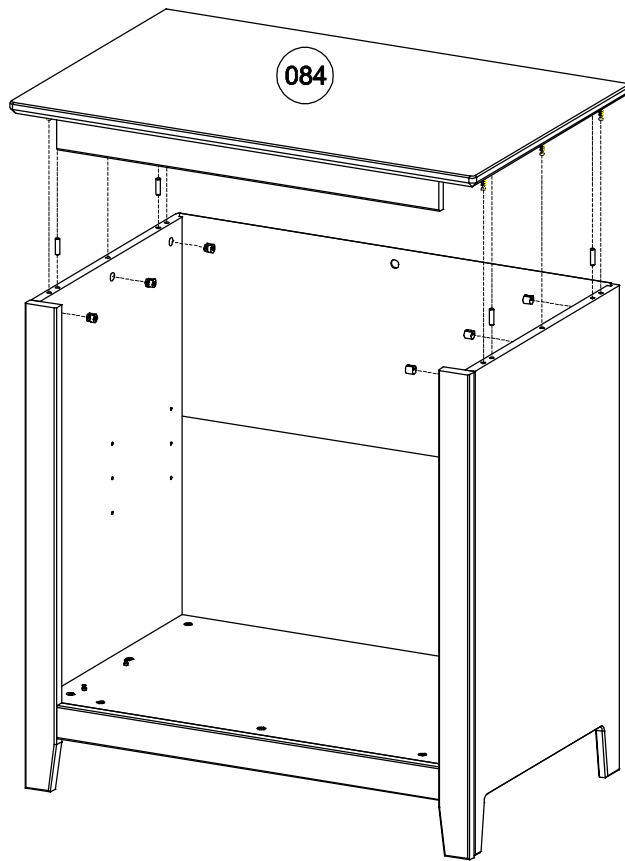

H1  x4
ø 8x30

11

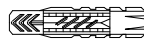

D31   x1

H8  x1
ø 6x35

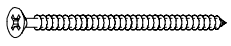
A69  x1
ø 4x60

12

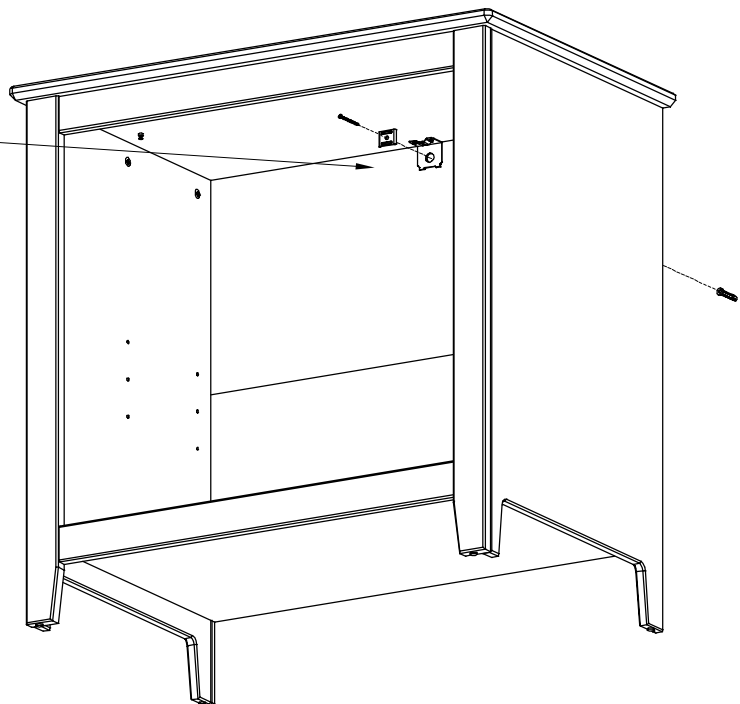
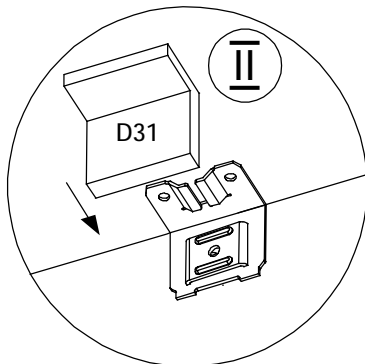
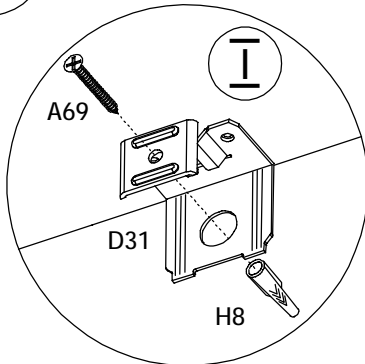
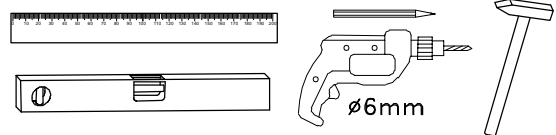

D20



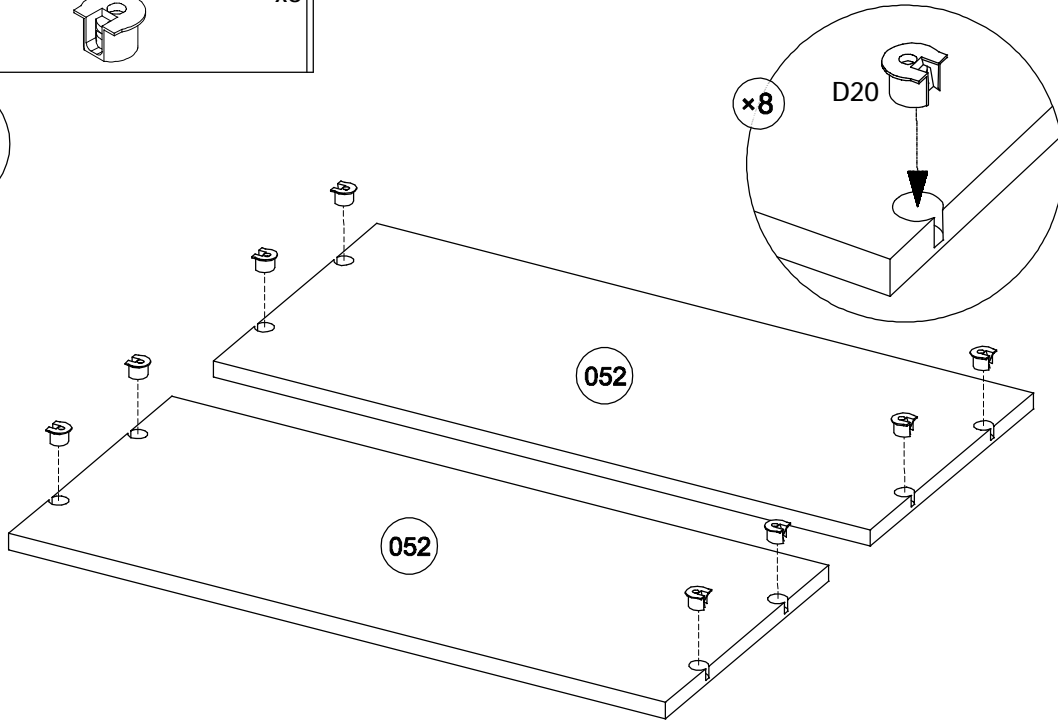

x8

13



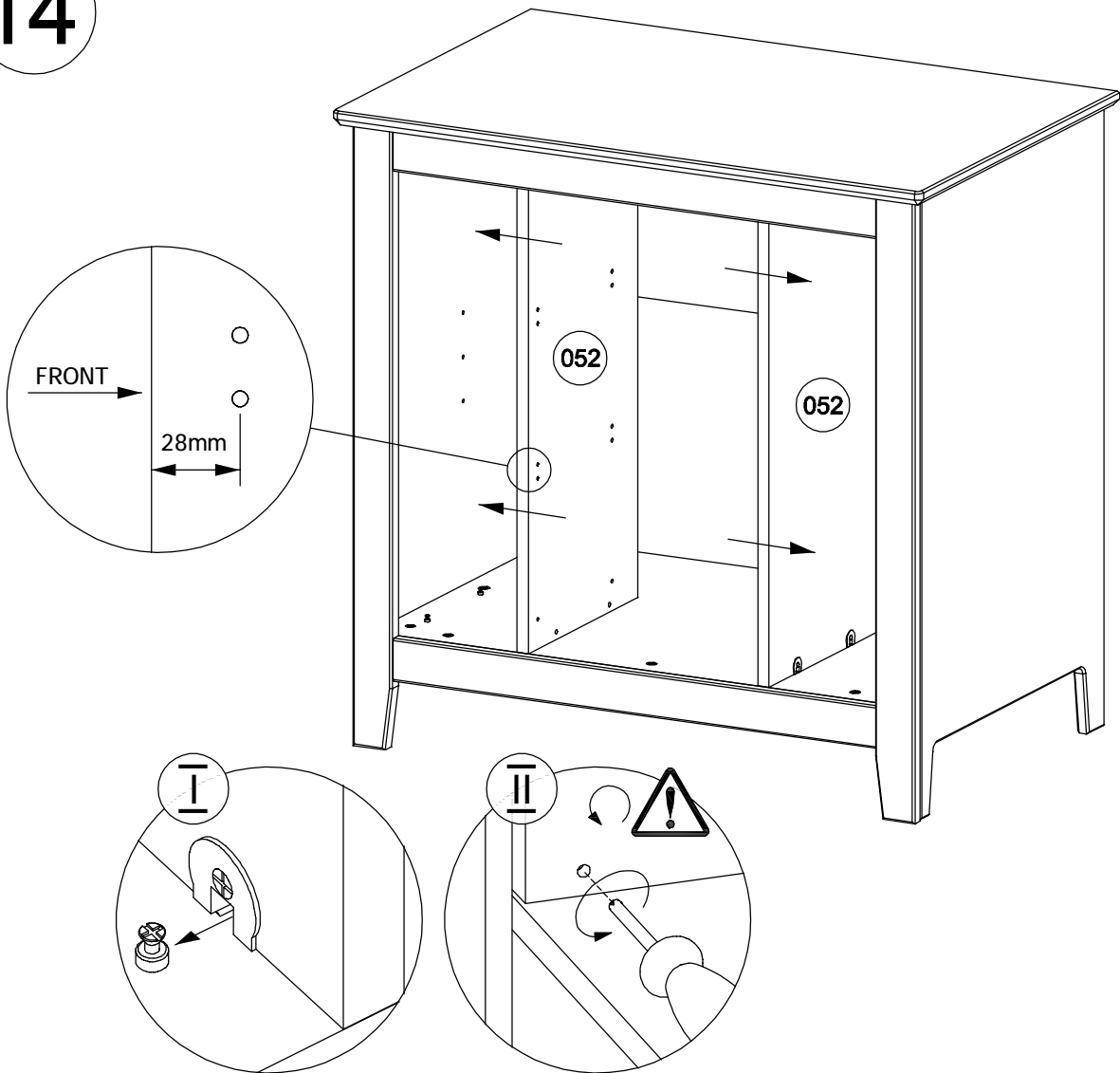

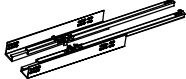

14

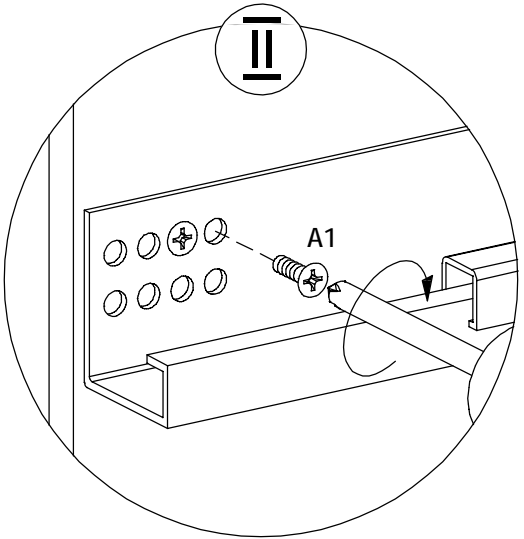
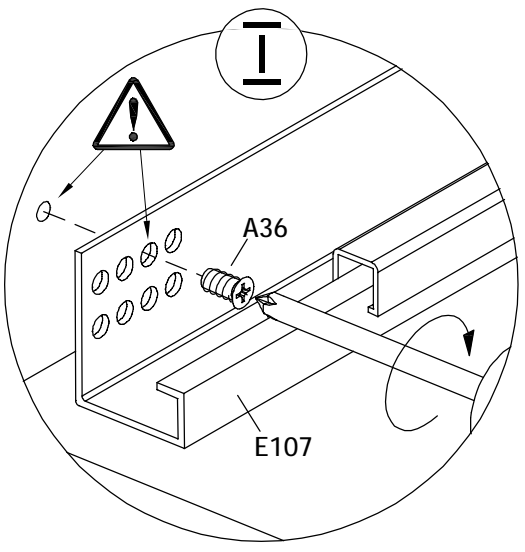
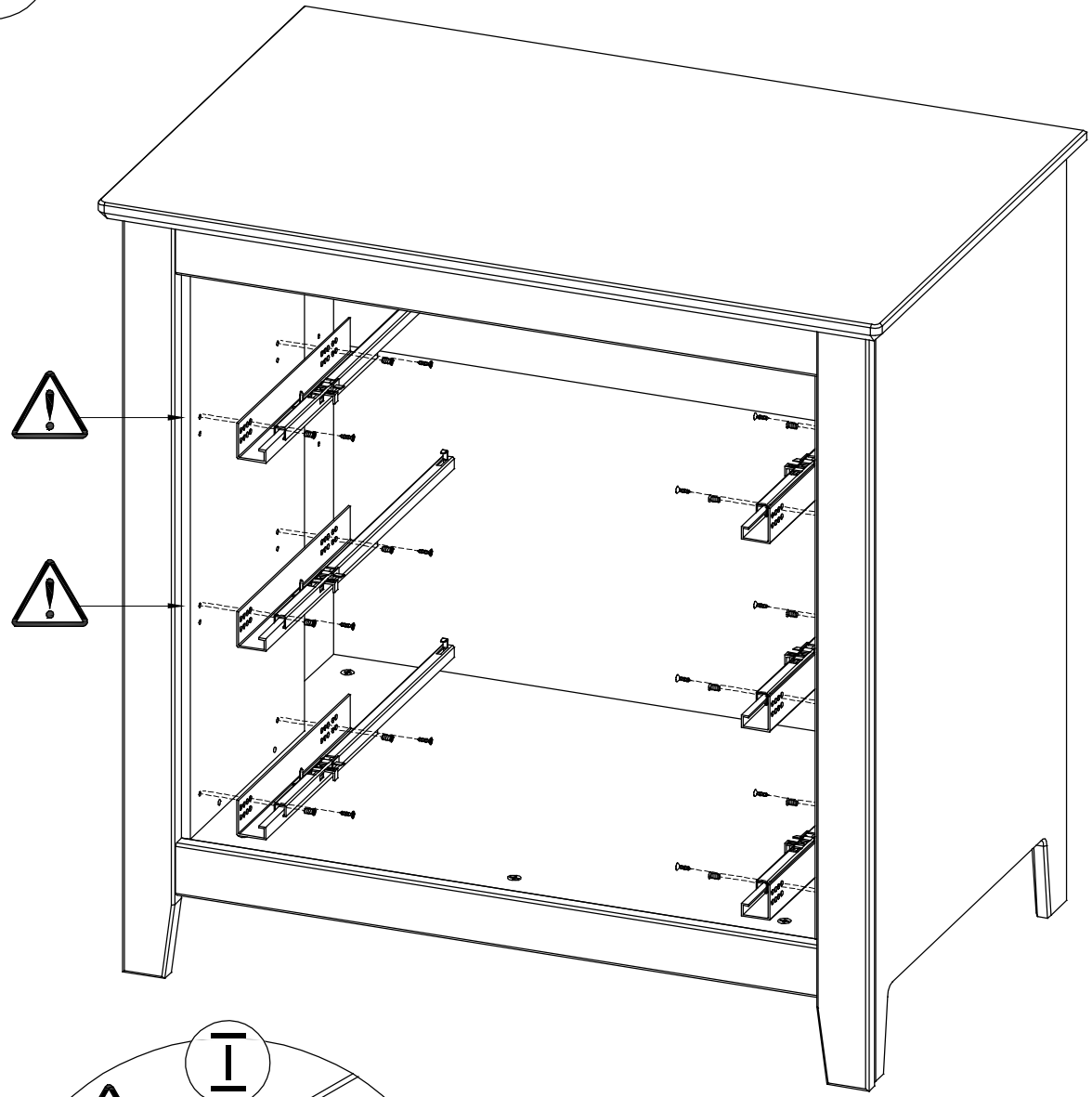

E107	 x3 535 mm	A36	 x12 ø 6x10,5	A1	 x12 ø 3,5x15
------	--	-----	---	----	---

15

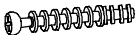

B100		x6 ø28x20	D2		x24 ø 5/11x34	D5		x24 ø15x12,5
------	---	--------------	----	---	------------------	----	---	-----------------

A3		x6 M4x23
----	---	-------------

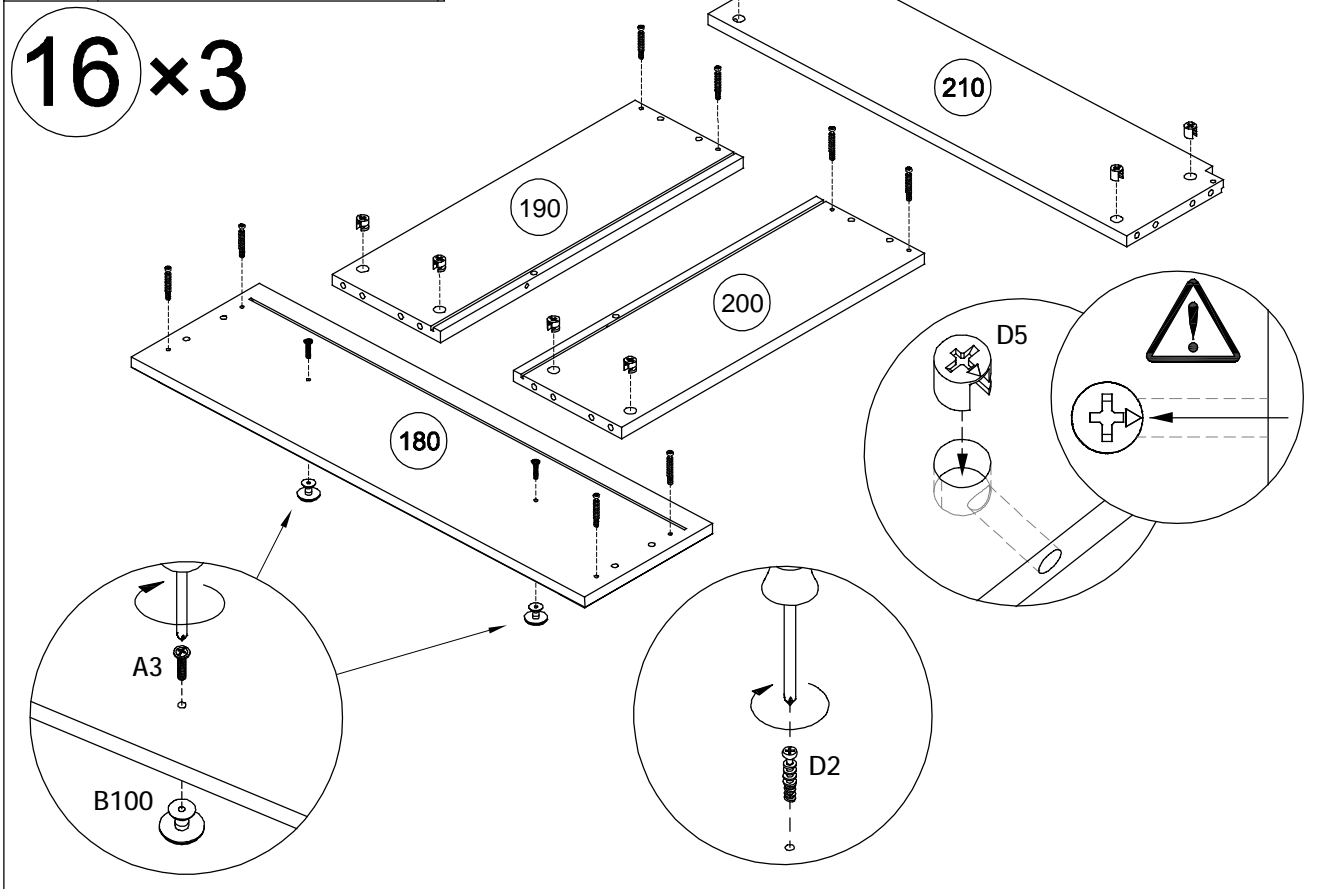

H1		x12 ø 8x30
----	---	---------------

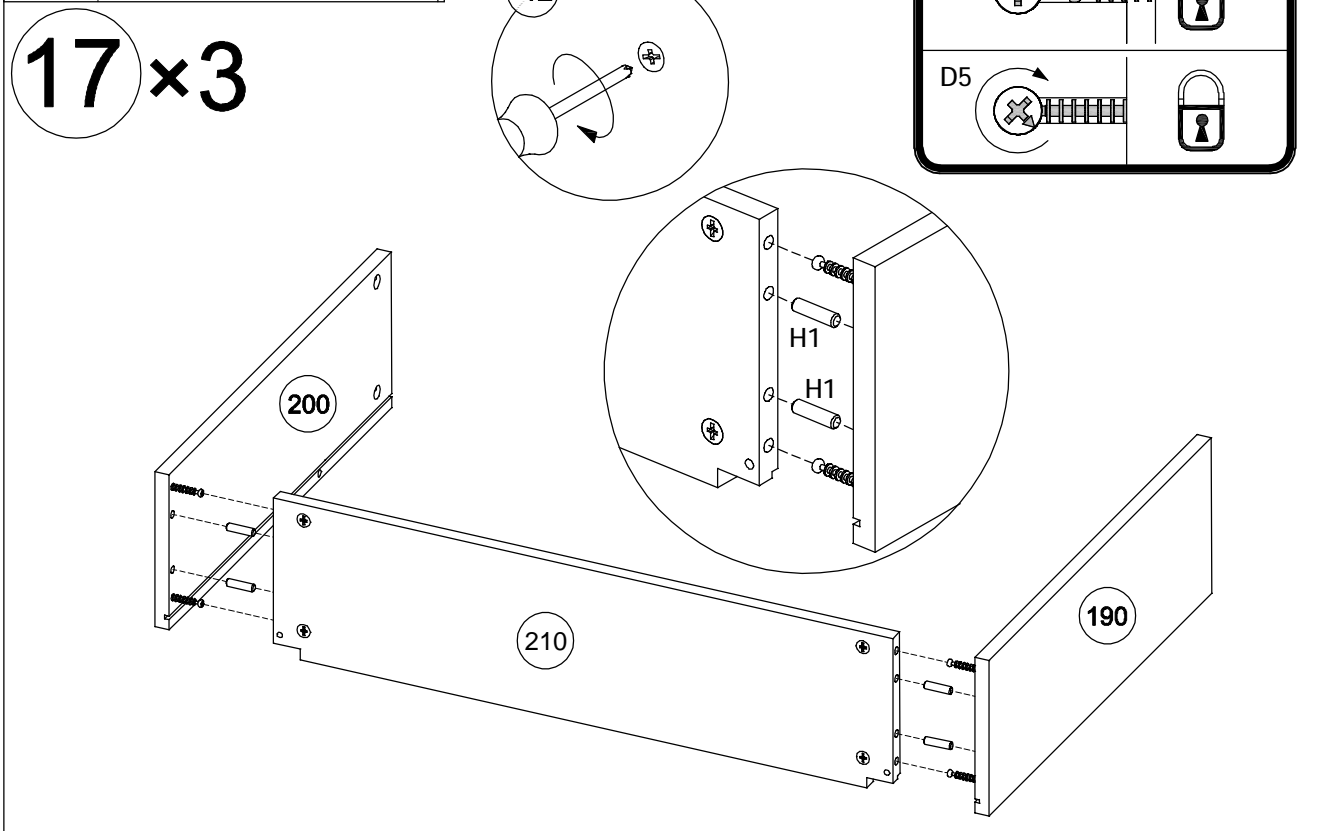

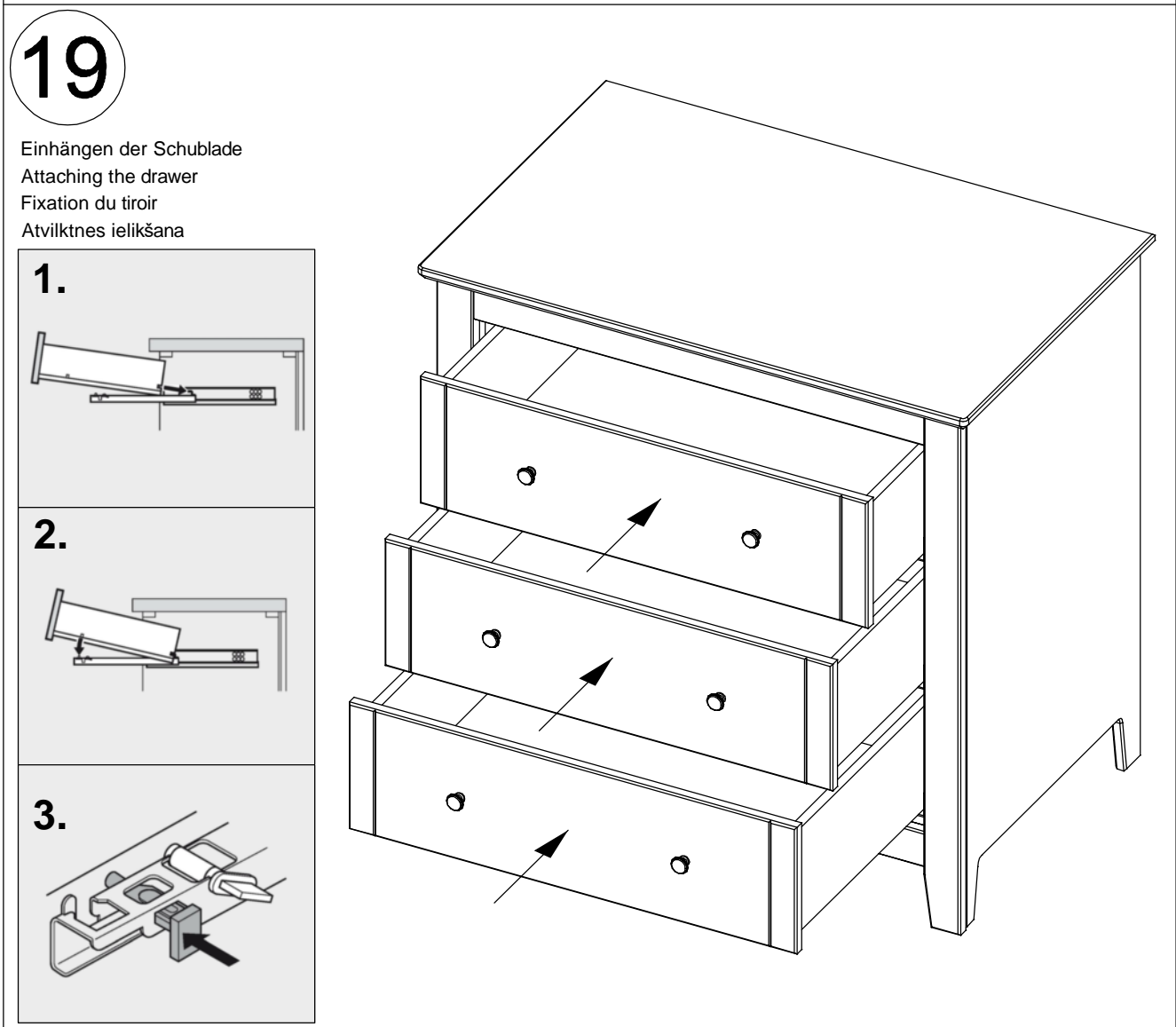
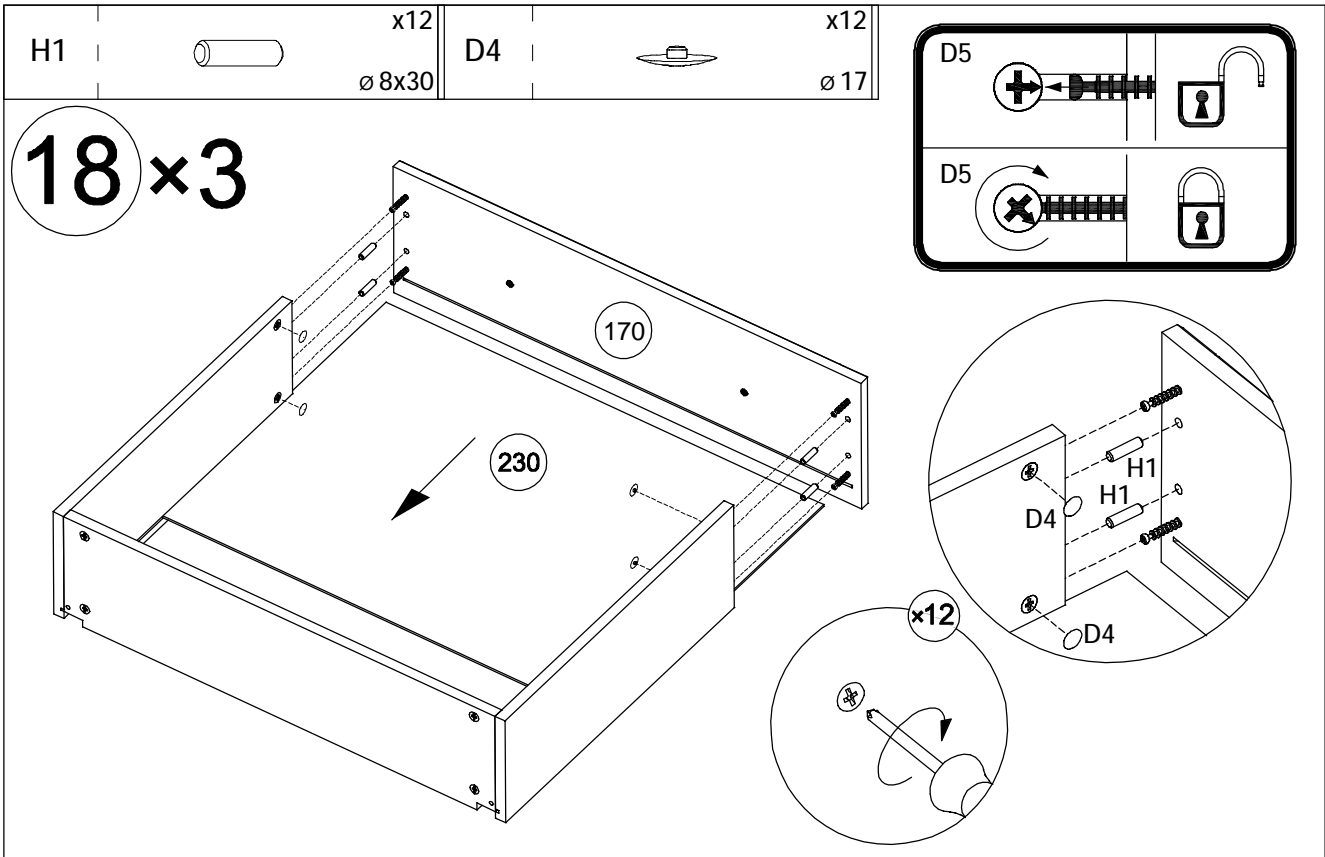

Einhängen der Schublade
Attaching the drawer
Fixation du tiroir
Atvilktnes ielikšana

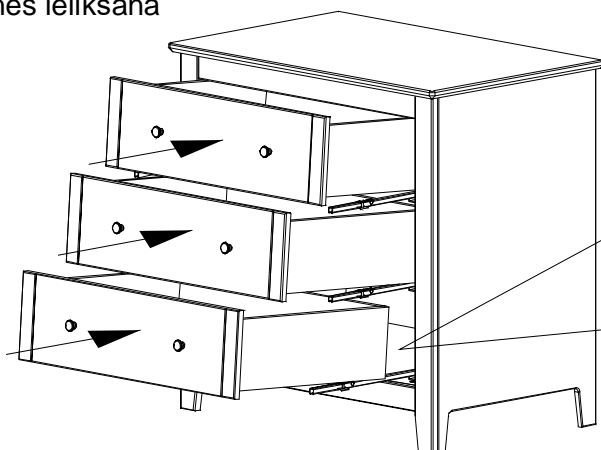

Hinteransicht des Schubkastens
Rear view of the drawer
Vue arrière du tiroir
Skats no atvilktnes aizmugures

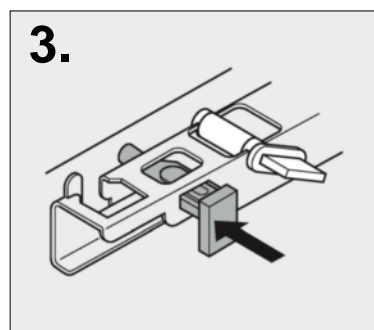
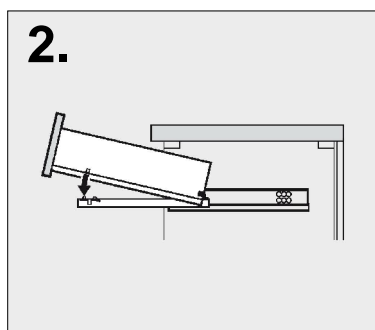
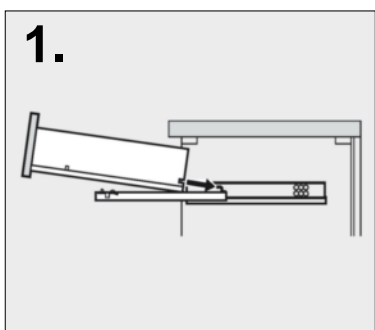
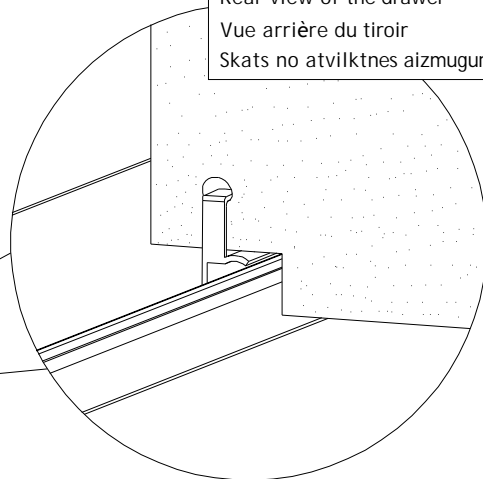

Aushängen der Schublade
Removal of drawer
Suppression de tiroir
Atvilktnes izņemšana

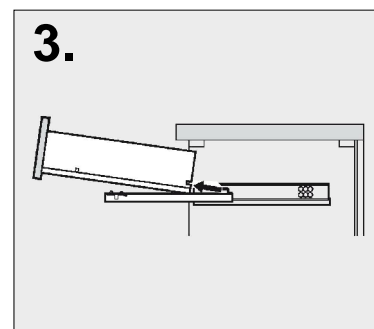
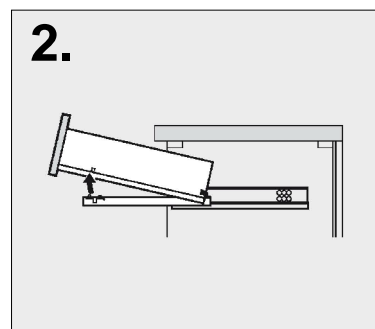
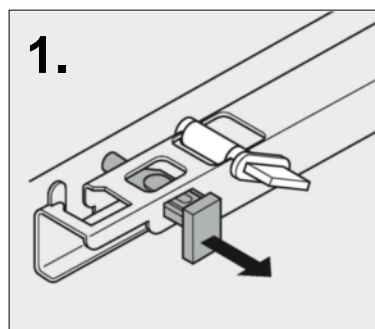

Höhenverstellung
Height adjustment
Réglage de la hauteur
Augstuma regulēšana

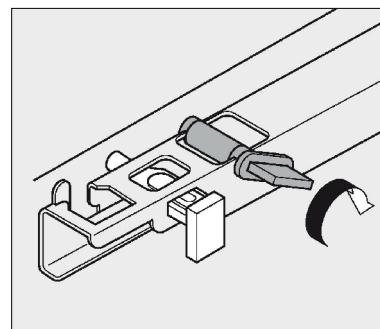
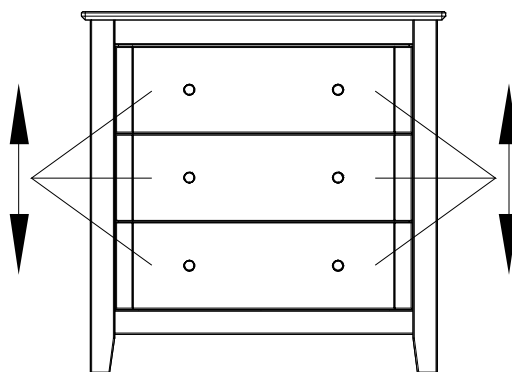

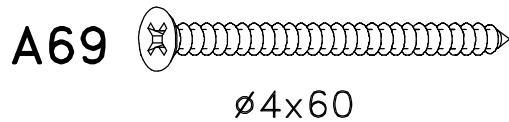
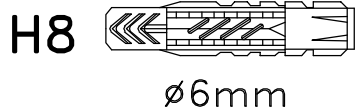

 $\varnothing 6\text{mm}$

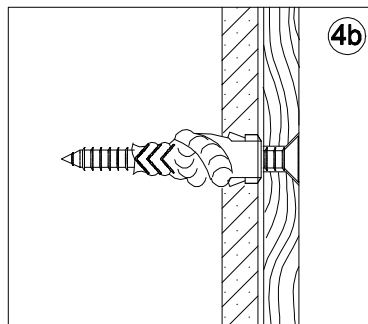
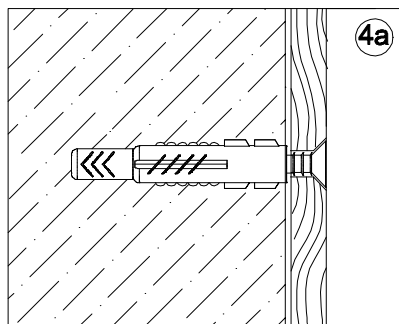
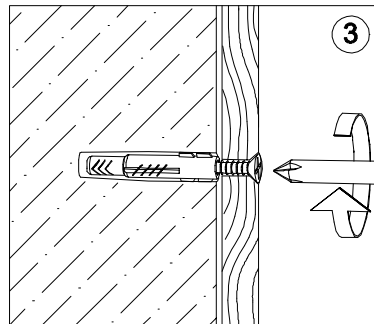
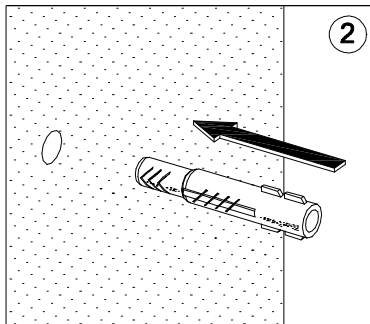
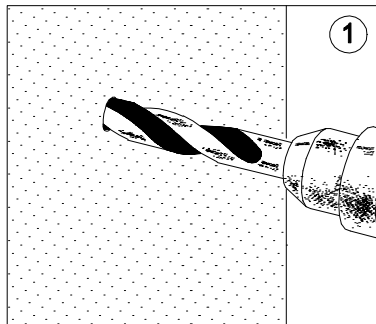

- D** **Achtung:** Die Befestigung des Möbelstückes an der Wand muss von einer fachkundigen Person vorgenommen werden, da für die Montage an die Wand angepasste Dübel erforderlich sind.
- GB** **Attention:** A qualified professional is required when mounting furniture to the wall since dowels corresponding to the wall are required for this.
- FR** **Attention :** La fixation du meuble contre le mur doit être effectuée par une personne compétente car, pour le montage mural, il faut utiliser des chevilles adaptées.
- LV** **Uzmanību:** Mēbeles montāžai pie sienas paredzēts izmantot speciālus dībeļus. Ietecams šo darbu veikt kvalificētam darbiniekam.